

# Voltage- and Frequency-Relay SPI1021

Grid- and Plant Protection according to CEI 0-21,  
with integrated Vector-Shift-Relay

## SPI1021



Dichiarazione di conformità  
alle prescrizioni alla Norma  
CEI 0-21.

The SPI1021 monitors voltage and frequency in plants for own generation of electricity. It fulfills the requirements of CEI 0-21. 3 selectable programs allow measuring 3 phases to neutral (4-wire mode), 3 phases phase-phase (3-wire mode) and single phase to neutral (2-wire). The SPI1021 can monitor all decentralized power, photovoltaic, wind or thermal plants, that feed in the low voltage and medium voltage grid. In applications with possible asymmetry >6 kVA, power balance has to be monitored extra.

With the integrated certified self test, the device can be used in plants < 6kVA.

All limits are preset according to CEI 0-21. They can be changed if required and be protected with a code and/or a seal.

A counter for alarms and standbys stores the last 100 events with reason and elapsed time. In addition the time the SPI1021 has interrupted the plant is recorded. All values can be displayed at the device and give the operator valuable information about the availability of the plant.

When the device has been installed, a self-test starts automatically. The self-test can be repeated when required. All values

of the test are stored and can be read out at the display.

- Monitoring of under- and overvoltage 15-520 V
- Measuring of 3 phase with or without neutral or single phase
- Monitoring of over- and underfrequency 45-65 Hz
- Monitoring of quality of voltage (10-minutes-average)
- Monitoring of vector-shift (connectible)
- Input IN2 for selection of frequency window
- Input IN3 for selection of mode transitory or definitive
- Input Y0/Y1 for monitoring function of connected switch (automatic detection of nc/no)
- Relay K2 picks up (on time <500 ms) only at failure at switch connected to K1
- 2 restarts at switch-on error of connected switch
- Selftest with storing of values
- Switching delays adjustable 0,05...130 s
- Switching-back-delays adjustable 0...999 s
- Different switching time according to type of alarm and selected mode
- Switch-on delay 300 s (adjustable)
- All parameters preset according to CEI 0-21
- Alarm counter for 100 alarms with value. Reason and elapsed time
- Recording of added time of alarms
- Input for standby (off time <50ms) with counter and recording of time
- Simulation for testing
- Sealing, all parameters can be read out while sealed
- Easy installation and programming with 3 preset programs
- Supply-voltage AC/DC 24-270 V
- Housing for DIN-rail-mount, 105 mm wide, mounting height 70 mm

Order-Number:

**S222300**

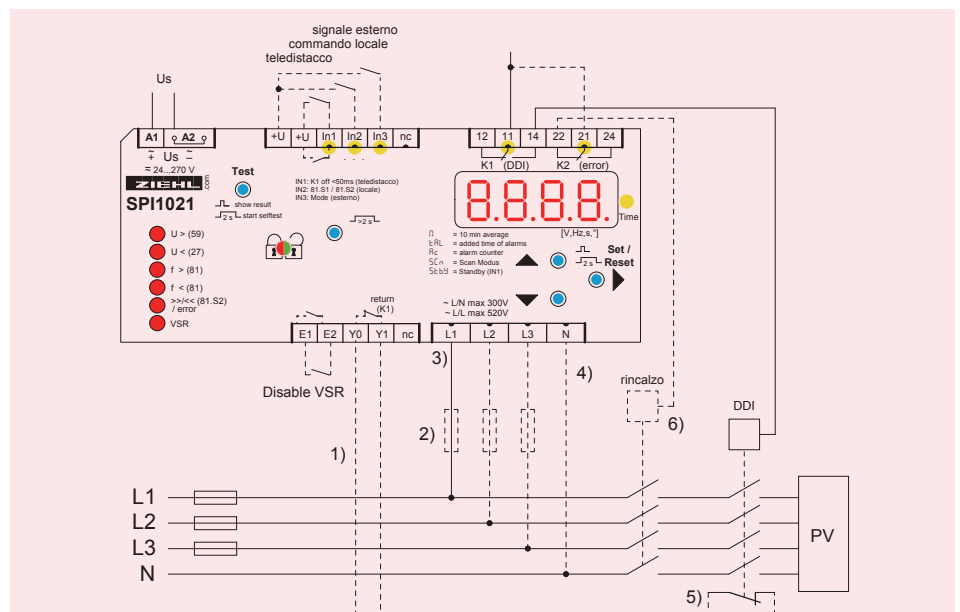

## Technical Data SPI1021

Power supply	Rated supply voltage $U_s$	AC/DC 24-270 V, 0/40...70 Hz, <5VA DC: 20,4...297 V, AC: 20,4...297 V
Relay output		2 change-over contacts
Measuring voltage	Voltage phase-phase Setting range phase-phase Voltage phase-neutral Setting range phase-neutral Measurement method	AC 15...530 V (< 5 V display 0) AC 15...520 V AC 10...310 V (< 5 V display 0) AC 15...300 V true RMS
	Hysteresis	adjustable 1,0...99,9 V
	Measurement accuracy (with neutral)	$\pm 0,6\%$ of measured value
	Measurement accuracy (without neutral)	$\pm 0,8\%$ of measured value
	Accuracy of display	>100V: $\pm 1$ digit (resolution 1 V) <100V: $\pm 1$ digit (resolution 0,1 V)
	Measurement functions	3-phase with / without neutral, single phase
	Switching-delay (dAL)	adjustable 0,05 ( $\pm 15$ ms)...130,0 s
	Switching-back-delay (doF)	adjustable 0 (= 40ms)...999 s
Measuring frequency	Measurement range Setting range Hysteresis Measurement accuracy Switching delay (dAL) Switching-back-delay (doF)	40...70 Hz 45,00...65,00 Hz 0,05...10,00 Hz $\pm 0,01$ Hz $\pm 1$ digit adjustable 0,05 ( $\pm 15$ ms)...130,0 s adjustable 0 (= 40ms)...999 s
Vector-Shift	Measurement range Measurement range Switching-delay (dAL) Switching-back-delay (doF) Delay at $U_s$ on	0...45,0° 2,0...20,0° < 50 ms adjustable 3...240 s adjustable 2...20 s
Digital inputs (INx)	Switching voltage + U Current INx	DC 15...37 V > 3 mA
Input Feedback contact	Switching voltage Y0...Y1 Current Y1 Switching time connected switches	DC 15...35 V > 3 mA adjustable 0,5...99,0 s
Housing	Design Dimensions (h x w x d) Wiring connection single strand Finely stranded with wire end ferule Protection housing Protection terminals Attachment Weight	V6 90 x 105 x 69 mm, mounting height 70 mm 1 x 4 mm <sup>2</sup> 1 x 2,5 mm <sup>2</sup> IP30 IP20 DIN-rail 35 mm according to EN 60 715 or screws M4 ca. 250 g