

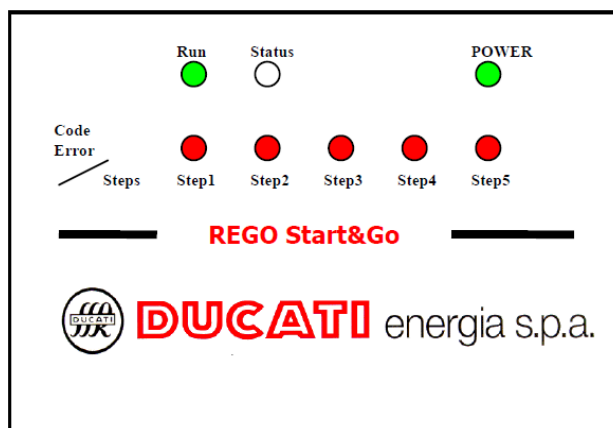

REGO Start&Go



USER MANUAL

Introduction

The **purpose** of the manual is to describe all of the steps required to commission and correctly operate the **REGO Start&Go** automatic power factor correction regulator, installed in the **DUCATI** energia power factor correction equipment.

Note: This manual refers to REGO Start & Go cod. 164352004A with serial number greater than D18170001 and to the replacement board¹ of the following codes

- Code 164382591 (SCH. REGO START&GO PESI 1-1-2)
- Code 164382601 (SCH. REGO START&GO PESI 1-2-2)
- Code 164382611 (SCH. REGO START&GO PESI 1-2-4)

Refer to the previous versions of this user manual for REGO Start&Go with serial number lower than D18170001



Note that the regulator is an integral part of the equipment and the configuration of the batteries was designed and implemented in DUCATI energia; the correct connection is represented by the varmetric insertion described below.

1. Connection mode of the device

1.1 Connection mode to the mains.

Below is a description of the connection mode to the mains of the REGO Start&Go regulator in combination with the Ducati energia electric board. Only the standard Varmetric insertion is used, where the linked voltage used is, for example, between the S/L2 phase and the T/L3 phase, while the CT (current transformer) in the remaining R/L1 phase line.

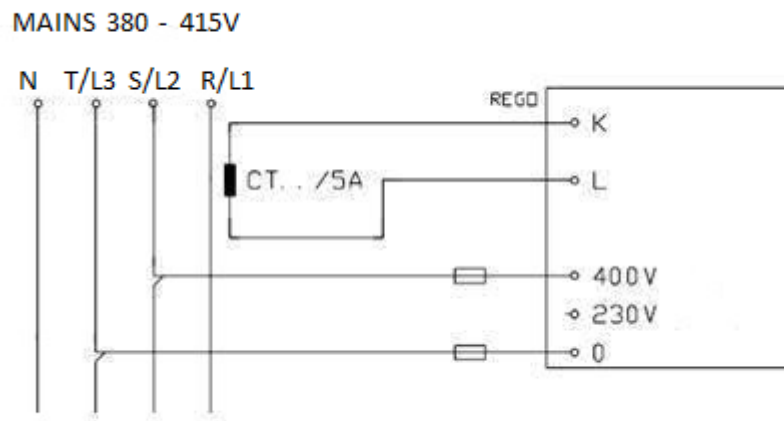



Figure 1 – Connection mode to the mains, connection FF1

¹ ALL THE SERIAL NUMBERS

Note: If the three-phase network is 230V L-L DO NOT connect the 400V pin, but the 230V pin



ATTENTION: This connection mode is **UNIQUE** therefore a different type of connection **DOES NOT allow** the instrument to operate correctly.
The customer **must** install the **CT** on the phase that is **NOT** used to power the device, for example **L1/R** as in figure above

1.2 CT connection

It is requested to connect only one C.T. in one of the positions marked as “OK” in the figure below. **The positions marked as “NO” are forbidden.** Connect “S1” to pin “L” and “S2” to pin “K” (see figure 3 to identify the pin names)

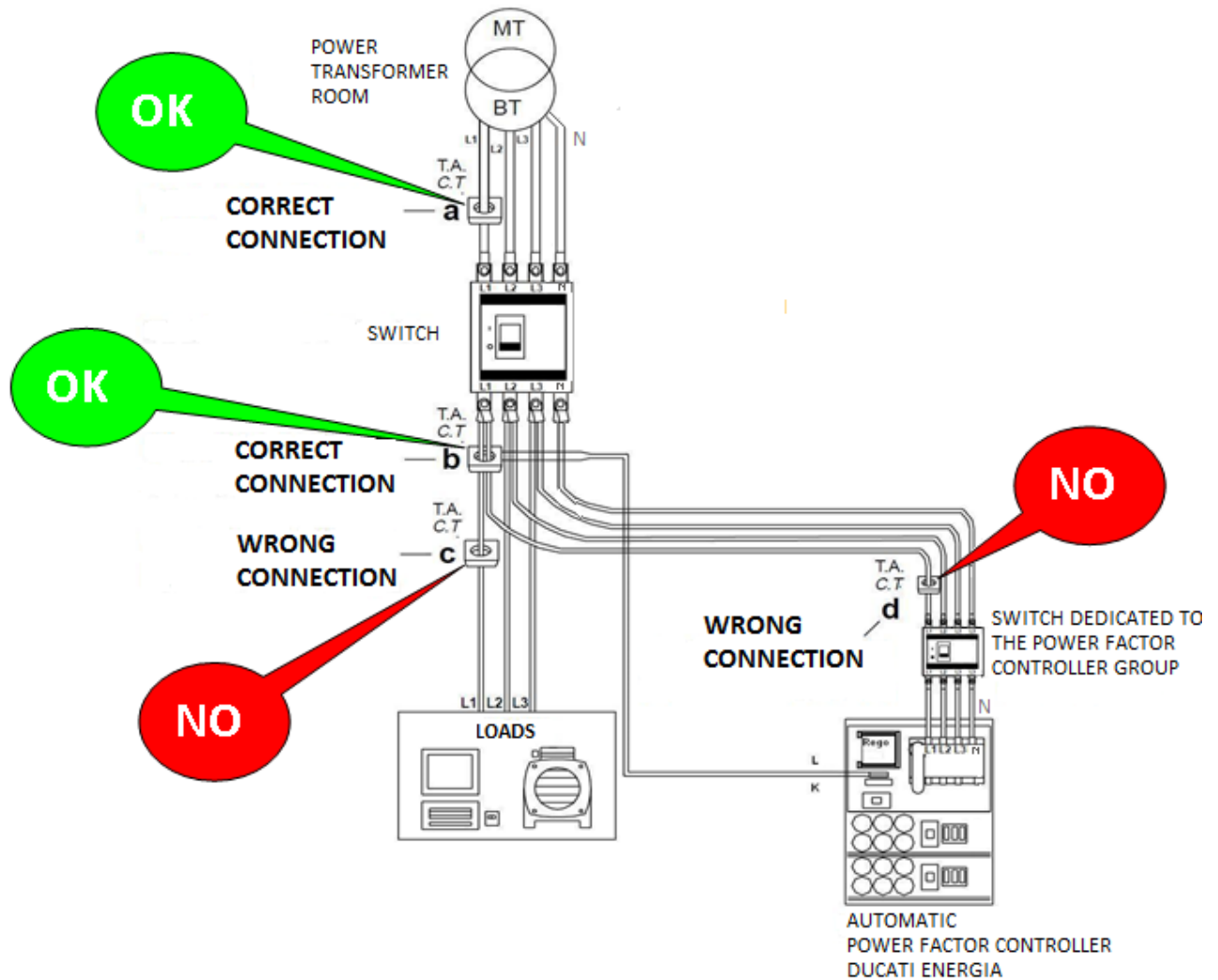

Figure 2 – Example of CT connections



ATTENTION: Note that the **CT** is not supplied and that therefore the customer must independently install and connect the most **suitable CT for the plant**, being sure to connect it **ONLY IN ONE** of the allowed position (a) or (b) in the figure above. For the choice of C.T. to be connected to the regulator:

- the **dimensions** must be such that the busbars or existing cables that compose the conductor of **ONE** phase can pass through.
- The full scale current of the **secondary** must be 5A
- The **primary** will have a full scale current 20% greater than the maximum current absorbable by the loads.
- **Precision class** required for the CT must be less than **class 1**

1.3 IN/OUT connector wiring

The meaning of the pins of the removable terminal boards is illustrated below. Check the correct connection of the cables before switch it on for the first time. Note: for models with only 3 relays the terminals relative to relay 4 and Relay 5 will not be available.

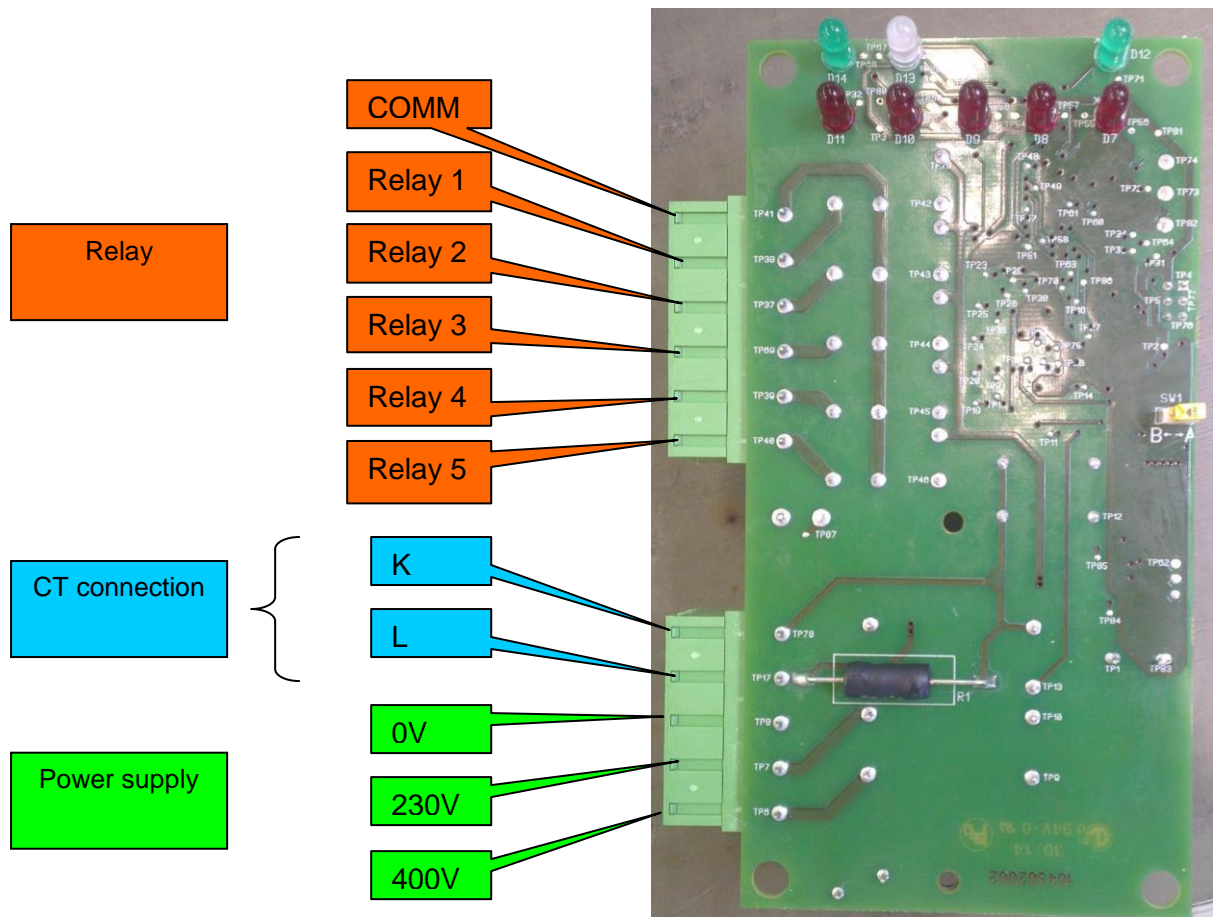

Figure 3 – Wiring of the board connectors

2. Self-diagnosis at start-up

Every time the equipment is switched on, REGO Start&Go runs a self-diagnosis on equipment's capacitors batteries detected faulty during power factor correction. The following are carried out in particular:

- Check that the **temperature** of the electric board is within the admissible range.
- Testing on **battery failures** and size and, in case of failure, checking restored operation by running 3 insertions of the failed battery. Batteries that are still found to be failed or a different size from expected are momentarily excluded from the power factor correction logic and re-tested the next time they are switched on.
- **SW1 switch position reading** (see Figure 4 below) for self-acquisition to check the request for a new battery acquisition made by the Customer (Chap. 3.2). Switch SW1 is positioned on the board inside the cabinet (Figure 4).

For the duration of the tests the “**Run**” led flashes while the “**Status**” led remains orange until it turns green or red at the end of the test (see Table 1, Table 2 and Table 3).

3. Commissioning

3.1 Self-diagnosis and Automatic battery acquisition

Only at the first commissioning, the regulator runs a **self-diagnosis** and an **automatic battery acquisition**.

It is not necessary to set the CT value because REGO Start&Go acquires it autonomously through a cyclical battery reading.



ATTENTION: Before proceeding with the steps described below **check** that the CT has been installed as shown in Figure 2. Also ensure that the connected load remains inductive and stable as long as the “Status” led is orange.



ATTENTION: If there is an **PHOTOVOLTAIC system**, be sure to momentarily **SWITCH IT OFF** during commissioning, to run the plant check in the absorption dial



ATTENTION: when commissioning the equipment, before it switches to the normal state of operation, it is necessary to wait for the REGO Start&Go regulator to finish the **automatic battery acquisition**

At power on with low current condition, REGO Start&Go shows a low current error (see cap.6) and it remains there as long as it exits the error condition and it starts self-diagnostics..

The self-diagnosis is composed by:

- Mains **frequency** reading: 50 Hz or 60 Hz.
- **Installation Tests on the CT:** CT not found; CT in wrong PHASE; CT in wrong POSITION; if these tests provide negative results the regulator locks in error status (see chap. 6).
- Check that the **mains voltage and current** are within the specified range, otherwise the regulator locks in error status (see chap. 6).
- Automatic adaptation of the **CT direction**.

If the self-diagnosis has a positive outcome, only when commissioning the equipment the first time, the automatic acquisition procedure of all of the batteries is carried out in sequence: every battery is connected and disconnected 3 times in a row and the sequence is repeated 4 times, with 30 s breaks in between (required to completely discharge the condensers).

Based on the regulator's status, the "Status" led (see Figure 5) is a different colour:

- Auto-diagnosis or Automatic battery acquisition in progress: steady **orange** "Status" led
- Auto-diagnosis ok or Correct operation without errors: steady **green** "Status" led
- Auto-diagnosis failed or Operation with errors: steady **red** "Status" led

(*) For the blocking tests REGO Start&Go shows the detected error code (see chap. 6) and it is accordingly necessary to switch the electric board off, perform the operations to remove the cause of the error and then switch the electric board back on again.

3.2 Total Parameter Reset

If, after servicing the cabinet to replace the board or to resolve operation anomalies, you intend to reset the parameters, do the following:

1. **Disconnect the power supply** to the cabinet and **open it** to access the Rego Start&Go regulator.
2. **Change** the position of **SW1** (see Figure 4). If it was previously in position A, move it to position B and vice versa. At the end, leave the switch in the position it was left in (without having to change its position at the end of the operation)
3. **Close** the cabinet back up again and **power** it.
4. REGO Start&Go will now start back up again as set forth in **Par.3.1**

The Figure 4 below illustrates the location of the **SW1** switch on the board.

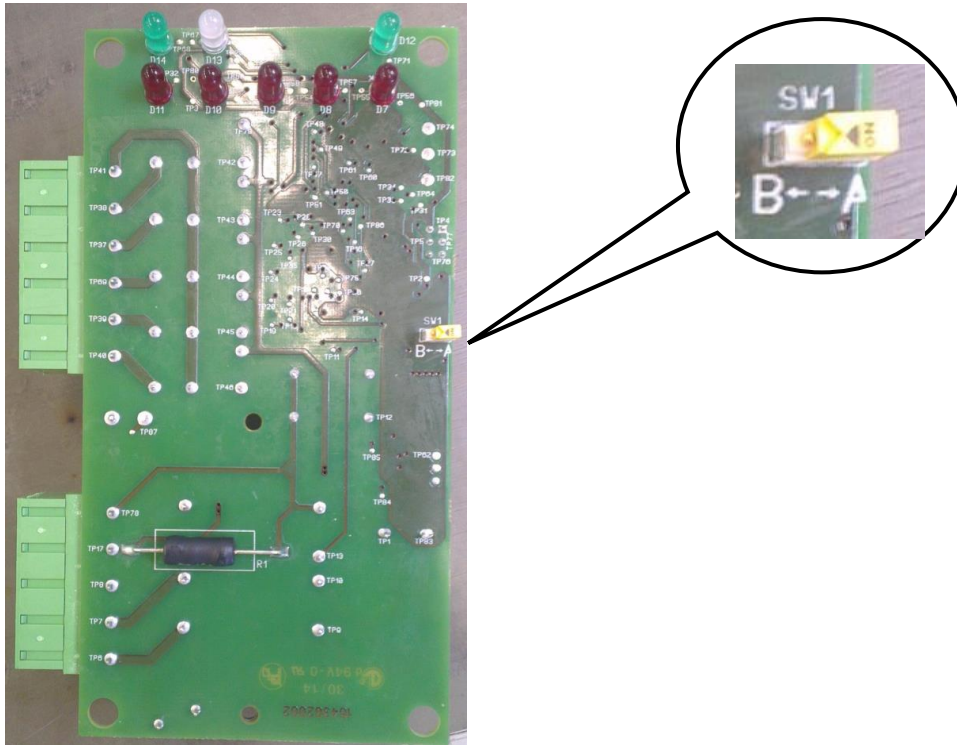

Figure 4 – Switch SW1 for Automatic Battery Acquisition

4. Regulator operation

4.1 Indicator leds

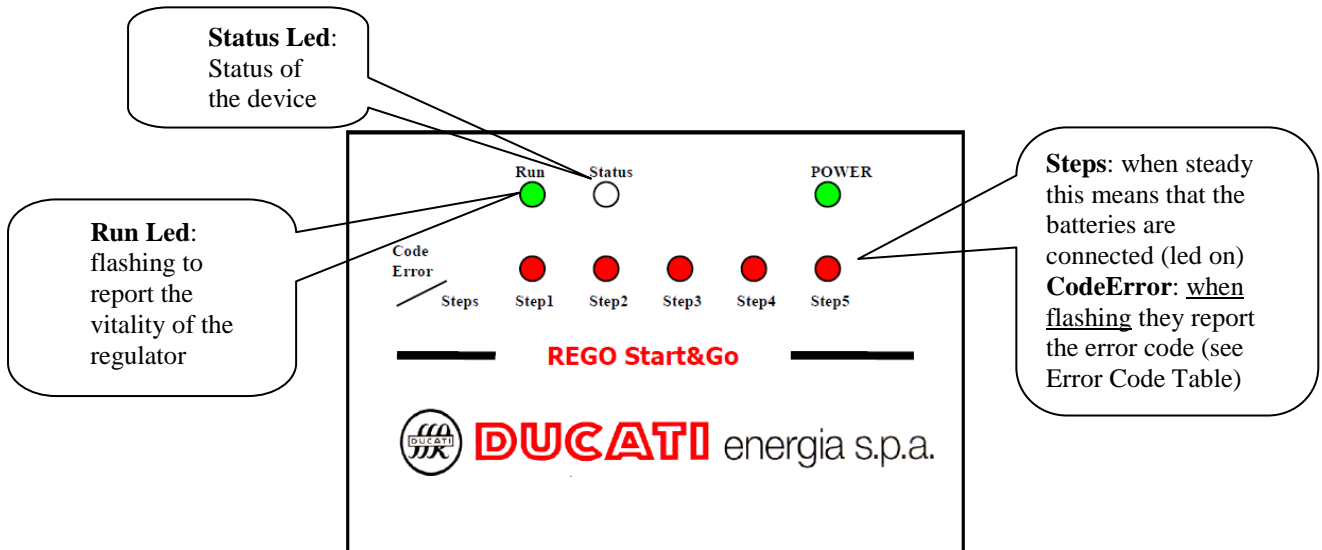

Figure 5 - View panel

- **CodeError/Steps:** When the Status Led is steady red, the flashing Leds (Step1..Step5) report the current error code (see Table 4), while the steady Leds

(Step1..Step5) report which batteries are connected (ex. Led1 Step1 steady on means that battery 1 is connected).

- **Status:** this reports the status of the regulator:
 - **Orange:** this means that the self-diagnosis that begins at start-up and automatic battery acquisition are in progress
 - **Green:** correct regulator operation (no errors)
 - **Red:** there are errors
- **Power:** This means that the device is powered.
- **Run:** When flashing it reports the device's vitality²

²Correct execution of the power factor correction programme on the internal micro-controller

5. Led signals pertaining to the operating statuses

Below are the various existing led signals based on the current status of Rego Start&Go. For all of the phases below, even if not described, the “POWER” led is always *steady Green* meaning that the board is powered.

5.1 Orange Status Led

Below is a list of the situations in which the “Status” led is steady **Orange**.

<p>Self-diagnosis: this is only carried out at the time of the first start-up (par. 3.1.) or after resetting the parameters (par. 3.2).</p>	<ul style="list-style-type: none"> - <i>Flashing green</i> “Run” led - <i>Steady orange</i> “Status” led - “Step1”..”Step5” leds stay <i>off</i> for at least 30s during testing, the same amount of time it takes for the batteries to discharge; when they are <i>steady on red</i> this means that the first battery is connected, to continue with further tests.
<p>Automatic battery acquisition: This phase is carried out immediately following the phase described above and is only carried out at the time of the first start-up (par. 3.1.) or after resetting the parameters (par. 3.2).</p>	<ul style="list-style-type: none"> - <i>Flashing green</i> “Run” led - <i>Steady orange</i> “Status” led - “Step1”..”Step5” leds, with <i>steady red</i> leds, report the timed connection of the various batteries in sequence, starting from Step1 up to Step3 (or Step5 in 5-step models), running 4 complete cycles, with a break of approx. 30s between cycles.
<p>Battery failure self-diagnosis: this is carried out every power on with a battery failure condition.</p>	<ul style="list-style-type: none"> - <i>Flashing green</i> “Run” led - <i>Steady orange</i> “Status” led - “Step1”..”Step5” leds, with <i>steady red</i> leds, report the timed connection of the failure batteries, starting from Step1 up to Step3 (or Step5 in 5-step models), running 3 complete cycles, with a break of approx. 30s between cycles.

Table 1. Orange led status

5.2 Green Status Led

Below is a list of the situations in which the “Status” led is steady **green**.

<p>Correct regulating operation: Value Measurement and Regulation Phase. No errors</p>	<ul style="list-style-type: none"> - <i>Flashing green</i> “Run” led - <i>Steady green</i> “Status” led - <i>Steady red</i> “Step1”..”Step5” mean that the batteries are connected
<p>End of self-diagnosis with positive outcome End of automatic battery acquisition with positive outcome A situation of error is resolved.</p>	<ul style="list-style-type: none"> - <i>Flashing green</i> “Run” led - <i>Steady green</i> “Status” led - “Step1”..”Step5” leds <i>off</i> mean that no battery is connected

Table 2. Green led status

5.3 Red Status Led

Below is a list of the situations in which the “Status” led is steady **red**.

<p>Error / alarm in progress: one or more errors have been detected</p>	<ul style="list-style-type: none"> - <i>Flashing green</i> “Run” led - <i>Steady red</i> “Status” led - “Step1”..”Step5” leds: every 5s they alternate between displaying steady Red leds (relative to the connected batteries) and displaying flashing Red leds (relative to the error code). <p>If there are several errors, they are displayed in sequence every 5s. If the type of error requires disconnecting the batteries, then during the display phase of <i>steady</i> leds they remain off.</p>
<p>End of self-diagnosis or Automatic battery acquisition with Negative outcome</p>	<ul style="list-style-type: none"> - <i>Flashing green</i> “Run” led - <i>Steady red</i> “Status” led - “Step1”..”Step5” leds: every 5s they alternate between displaying the error code with flashing Red leds, <p>If there are several errors, they are displayed in sequence every 5s If no batteries are connected, then during the display phase with <i>steady</i> leds they remain off.</p>

Table 3. Red led status

6. Errors/Alarms view

6.1 ERRORS/ALARMS code

Below is a table stating the combination of leds associated with the error number and its meaning
ATTENTION! THE LED CONFIGURATIONS ILLUSTRATED BELOW STAND FOR AN ERROR/ALARM ONLY IF THE LEDS ARE FLASHING



















































Step1	Step2	Step3	Step4	Step5	error no.	ERROR/ALARM DESCRIPTION
					1	Current of secondary CT too low
					2	Current of secondary CT too high
					3	Internal temperature too high
					4	Input voltage too high
					5	Input voltage too low
					11	Insufficient reactive power of equipment
					12	No current from CT secondary
					13	CT primary on wrong phase
					14	CT in wrong position
					15	Incorrect reactive power on condenser arrays

Table 4. error codes

6.2 Error codes and actions taken by the regulator

error no.	<i>Type of detected error and list of taken actions</i>
1	<p>Current too low: the Input current to the instrument is below the bottom limit of 100 mA.</p> <p>“Status” led is steady red “Step1..Step5” leds flash as set for error no. = 1 in Table 4</p> <p>If the error persists for 10 sec Rego Start&Go disconnects the batteries in sequence. The batteries remain disconnected for at least 30 sec (battery discharge time) or at least as long as the error persists. The error is no longer reported when the error condition disappears.</p>
2	<p>Current too high: the input current to the instrument is higher than the top limit of 5.1A.</p> <p>“Status” led is steady red “Step1..Step5” leds flash as set forth for error no. = 2 in Table 4</p> <p>If the error persists for 10 sec Rego Start&Go disconnects the batteries in sequence. The batteries remain disconnected for at least 30 sec (battery discharge time) or at least as long as the error persists. The error is no longer reported when the error condition disappears.</p>
3	<p>Internal temperature too high: the temperature reading on the board is greater than 60°C.</p> <p>“Status” led is steady red “Step1..Step5” leds flash as set forth for error no. = 3 in Table 4</p> <p>If the error persists for 10 sec Rego Start&Go disconnects the Batteries in sequence. The error condition is resolved only if the temperature drops below 50°C, otherwise the state of alarm persists with the batteries disconnected. There is therefore a hysteresis from 60°C to 50°C.</p>
4	<p>Voltage too high: the input voltage to the device is greater than the top limit of 460V</p> <p>“Status” led is steady red “Step1..Step5” leds flash as set forth for error no. = 4 in Table 4</p> <p>If the error persists for 10 sec Rego Start&Go disconnects the Batteries in sequence. The error condition is resolved as soon as the voltage drops below this threshold.</p>
5	<p>Voltage too low: the input voltage to the device is lower than the bottom limit of 340V</p> <p>“Status” led is steady red “Step1..Step5” leds flash as set forth for error no. = 5 in Table 4</p> <p>If the error persists for 10 sec Rego Start&Go disconnects the Batteries in sequence. The error condition is resolved only if the voltage value rises above this threshold.</p>
11	<p>Insufficient reactive power of equipment: measured in $\cos(\phi)$ it is below the threshold of 0.95</p> <p>“Status” led is steady red “Step1..Step5” leds flash as set forth for error no. = 11 in Table 4</p> <p>This error occurs when, due to an insufficiently sized cabinet, or not sufficient for the requirements of the plant (for example due to a failed battery), an unavailable battery would be necessary or you are in a situation where the smallest battery would place the plant in capacitive; in both cases the error only applies if the $\cos\phi$ is below the 0.90-1 range. With this error no battery disconnecting action taken. The error is no longer reported when the error condition disappears.</p>
12	<p>No current from CT secondary: the value of the input current reading to the instrument is zero.</p> <p>“Status” led is steady red “Step1..Step5” leds flash as set forth for error no. = 12 in Table 4</p> <p>If the error persists for 10 sec Rego Start&Go disconnects the batteries in sequence. The batteries remain disconnected for at least 30 sec (battery discharge time) or at least as long as the error persists. This can happen even if the CT is set up in the wrong POSITION, for example in the POWER FACTOR CORRECTION branch. The error is no longer reported when the error condition disappears or, only in the case of CT in incorrect POSITION, it is resolved by switching off the system and removing the cause of the blocking error</p>
13	<p>CT primary on wrong phase:</p> <p>“Status” led is steady red “Step1..Step5” leds flash as set forth for error no. = 13 in Table 4</p> <p>This error occurs when the CT connection was set up incorrectly (the connection must be set up as shown in Figure 1). Attention! This error could occur also with a correct connection but with a capacitive load during self-diagnosis. It is necessary to switch the cabinet off, check the connections, remove the cause of error and turn the system back on again.</p>

14	<p>CT in wrong CT position:</p> <p>“Status” led is steady red “Step1..Step5” leds flash as set forth for error no. = 14 in Table 4</p> <p>This error occurs when the CT connection was set up incorrectly (for example, it was connected as shown in position “c” or “d” of Figure 2)</p> <p>It is necessary to switch the cabinet off, check the connection, remove the cause of error and turn the system back on again.</p>
15	<p>Incorrect reactive power on condenser arrays:</p> <p>“Status” led is steady red “Step1..Step5” leds flash as set forth for error no. = 13 in Table 4</p> <p>This error occurs when, following an automatic battery acquisition at start-up, the weights measured for the batteries do not match the nominal factory values. All errors relative to failed batteries will be reported as this type of error</p> <p>Turn the equipment off and back on again in the case of first automatic acquisition Switch it off, move the jumper and restart the equipment for automatic acquisitions after the first one</p>

Table 5. description of errors and relative corrective actions

7. Technical Features of the Rego Start&Go Board

3/5-Battery Rego Start&Go Power Supply Circuit	
Nominal Supply Voltage	400V \pm 15% 230V \pm 15%
Frequency	50Hz or 60 Hz (read automatically by the instrument)
Absorbed Power	7 VA max
Protection	F1 Self-resetting ceramic resistor on the board (It is nevertheless advisable to install an external 200mA T fuse)
Current input	
Nominal Current	5A
Operating Range	0.10A \div 5.1A
Maximum Absorbed Power	1,4W
Measurement and Control Data	
Type of measurement	Measurement of the reactive current at the voltage zero-crossing
Relay Output	
Number of Outputs	3 or 5
Contact Status	NA
Type of contacts	6A - 250Vac 2A – 400Vac
Rated Voltage/Max for Operation	250Vac / 440Vac
Interface for testing	
Type	TTL port for internal use
Ambient Operating Conditions	
Operating Temperature	0°C \div +60°C
Storage Temperature	-20°C \div +70°C
Connections	
Terminal Type	with removable screw
Conductor size	2.5mm ² max
Protection	
Degree of Protection of Board	IP00
Installation	
Type of Installation	Installation on internal cabinet support
Clamping to support	4 M4 clamping screws
Overall dimensions LxDxH (mm)	780x500x1450

8. Alarm thresholds and intervention times

Alarm thresholds	
Minimum / Maximum Input Voltage	340V / 460V on input 400V 196V / 264V on input 230V
Minimum / Maximum Input Current	0.10A / 5.1A
Alarm/Hysteresis Temperature	+60°C / Hysteresis between +50°C ÷ +60°C
Intervention times	
Wait time for a battery to discharge	30s
Insertion time for battery connection or disconnection	30s



Via M.E. Lepido, 182
40132 BOLOGNA - Italy
Tel.: 0039 051 64 11 511
Fax.: 0039 051 64 11 690
www.ducatienergia.com
Email: info@ducatienergia.com