

## SENSING & MONITORING RELAYS



TELE offers the widest range of products with the following performance features:

- Measurement of one or more quantities such as voltage, current, temperature and filling levels
- Internal or external power supply (e.g. 24 V DC)
- Monitor the voltage of ordinary mains grids at 230/400 V or 240/415 V as well as special industrial power supplies at 400/690 V
- Various forms of housing for control engineering, industrial systems and machine building as well as building installations; variants available for DIN rails, front installation or an 11-pole plug-in base

The robust design with generous terminal space throughout ensures very good usability and installability.

## OVERVIEW

		Page
<b>Monitoring Relays</b> <i>WatchDog</i>	Introduction	10
	<b>Selection matrix</b>	Quick, explicit and time-saving to the right product.
<b>Function overview</b>	Explanations of important terms	16
<b>Industrial Series: GAMMA</b>	- Voltage 3-phase	17
	- Voltage 1-phase	27
	- Current 1-phase	29
	- Current 3-phase	33
	- Temperature	39
- Level	41	
<b>Industrial Series compact: DELTA</b>	- Voltage 3-phase	49
	- Voltage 1-phase	53
	- Current 1-phase	55
	- Temperature	57
	- Level	59
<b>Plugable Series: KAPPA</b>	- Voltage 3-phase	61
	- Voltage 1-phase	61
	- Current 1-phase	61
<b>Installation Series: ENYA</b>	- Voltage 3-phase	63
	- Voltage 1-phase	63
	- Current 1-phase	77
	- Temperature	79
	- Level	81



**WELCOME TO THE  
WORLD OF THE  
WATCHDOGS**

The monitoring relays with the WatchDog label can display electrical values such as current, voltage, power factor, power performance, conductivity, resistance, temperature etc., meaning these can be monitored based on a limit value and deviations displayed on a message contact.

The housing is already a sign that the system has a robust design. The overvoltage category is consistently indicated with 3 so that industrial network environments do not present a problem. With the disruptive influences burst and surge, the normative requirements are more than fulfilled. The operating safety of

the devices is thus ensured even with high disruption potential.

One difference that makes a difference. The temperature range in which the devices can be operated is between -25°C and +55°C.

The spacious operating front permits the accommodation of many setting options and display elements. A clear display with a separate LED for each operating mode is thus possible. There is only one rule here, and this has been valid with TELE for years: flashing LED means 'time running', continuously illuminated LED means 'time expired'. The operating elements have a flush arrangement in the

front, whereby up to 5 setting elements are possible in a 22.5 mm construction width. This permits maximum functionality on minimum space. As supply variants for the auxiliary voltage, CoolZoom with 24-240VAC/DC or the power modules with nominal voltages of up to 400V(TR2) or 500V(TR3) are available.

The Watchdogs are now also being used in the installation construction form thanks to the ENYA series. With up to 5 setting elements, an excellent operating comfort can be reached in this construction form too that is supplemented by up to four display elements.

These can also serve as a diagnosis

display in ongoing operation, in order to e.g. recognise in which phase the breakdown has occurred. ENYA devices can fit in every energy distribution cabinet and are thus ideally suited for use in building automation and control systems. They can be used to protect against an unwanted operating status, the detection of consumption points that are switched on or for classical control tasks. The application areas range from the monitoring of a four-wire network via one-phase monitoring applications to DC monitoring of battery-buffered systems. A diversity of current and voltage monitoring relays in one- and three-phase design are

available. The supply with these devices is integrated into the measuring circuit to save clamp connections.

# WatchDog



**coolZoom**

The components mounted in a switching cabinet lead in total to a substantial heat development that has a negative impact on the lifecycle of the entire control unit. Through the use of state-of-the-art switching power supply technology, TELE reduces the energy consumption and thus also the heat development. The typical power consumption of the new products thus lies below the 1W mark – simply 'cool'. The lower operating temperature firstly has a positive effect on the lifecycle and reliability of the components and secondly results in substantial savings potential in the switching cabinet air climate control system and ventilation. Another benefit is demonstrated in the use of products in battery-buffered systems. Due to the lower power consumption, the battery

can be designed in a smaller size with extended follow-up time.

With their extreme adaptability (zoom) to any voltage supply

in the range of 24 to 240VAC/DC, generous tolerance ranges (20.4 to 264VAC or 19.2 to 300VDC) and their usage options in the frequency range of 16 2/3 to 400Hz, the devices from TELE are suitable for any conceivable application.

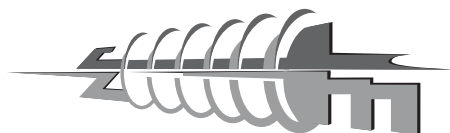

**PowerModules**

In a simple and cost-effective manner, you adapt the WatchDog monitoring relays and load sentinels and the timing relays of the GAMMA series to the respective supply voltage. The plug-in power modules TR2 and TR3 are available for this and they only have to be inserted into the lateral supply slot of the devices.

The power modules TR2, with selectable nominal voltages of 12 to 440VAC, are envisaged for designs in 22.5mm construction width, while the power modules TR3 with nominal voltages of up to 500 V are suitable for types with a 45-mm wide housing. The supply voltage can therefore also be taken up by the outer conductor voltage if a neutral cable is not necessary in the application. The power modules work particularly 'quietly' in the

network, which means they are entirely suited for class B applications according to EN 55011 (living area). Another advantage: In the event of maintenance, the plug-in power module can be quickly and conveniently replaced.

You simply order the right plug-in power modules for your application separately.

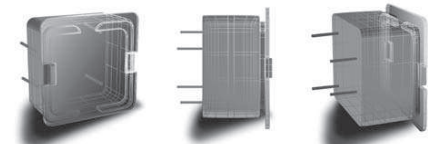





# FUNCTIONS- OVERVIEW

## OVER

The output relay remains switched on until the monitored value exceeds the maximum value. As soon as the monitored value falls below the minimum value, the output relay switches to the on position again.

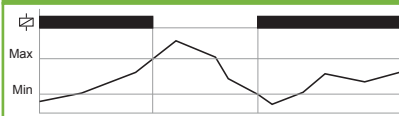

## WIN

The output relay remains switched on until the monitored value lies within the defined window. As soon as the monitored value enters the defined window again, the output relay switches to the on position again.

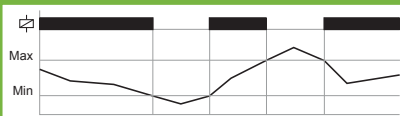

## UNDER

The output relay remains switched on until the monitored value falls below the minimum value. As soon as the monitored value exceeds the maximum value, the output relay switches to the on position again.



## DELAY

If the monitored value leaves the selected range, the output relay only switches to the off position following expiry of the trip delay.

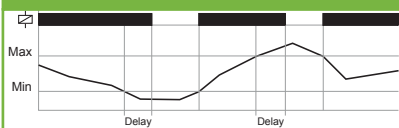

## ON-DELAY

The output relay switches on if the monitored value is within the selected range during the defined time period.

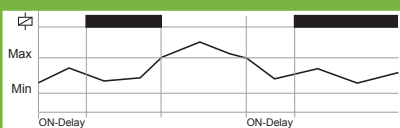

## LATCH (Fault latch)

If the device detects a fault, the output relay only switches on again when the fault latch has been reset. The fault latch can be reset by means of an internal or external reset button or by interrupting the supply voltage.

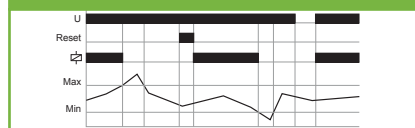

## START-UP

The output relay switches on when the supply voltage is applied. Changes to measured variables have no impact on the setting of the output relay during start-up suppression.



## I=0 Detection

Deactivated consumers are detected with I=0 detection. As soon as the current flow is supplied again, the measurement cycle commences again with the expiry of the defined start-up suppression.







# Sensing & Monitoring Relays Series GAMMA

Voltage monitoring in 3-phase mains

# WatchDog



- Multifunction
- Monitoring of phase sequence and phase failure
- Asymmetry detection switchable
- Connection of neutral wire optional
- Detection of loss of neutral wire
- Fault latch (G4PM)
- Supply voltage selectable via PowerModules or by zoom voltage 24 to 240V AC/DC
- 1 CO contact; 2 CO contacts
- Width 22,5mm or 45mm; Industrial design

types

G4PM690VSYL20

G4PM500VSYL20

G2PM400VSY20  
24-240V

G2PM400VSY20

G2PM400VSY10

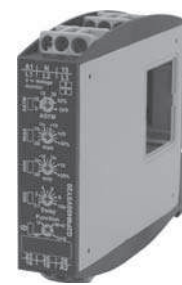

Art.No. (PQ1)

2394500

2394501

2390505

2390504

2390500

Art.No. (PQ10)

-

-

-

-

-

EAN13-Code

900866200296

900866200297

900866200284

900866200281

900866200276

Measured variable

3(N)~  
AC Sinus (48 to 63Hz)

3(N)~  
AC Sinus (48 to 63Hz)

3(N)~  
AC Sinus (48 to 63Hz)

3(N)~  
AC Sinus (48 to 63Hz)

3(N)~  
AC Sinus (48 to 63Hz)

Measured range

$U_N = 690/400V$   
terminals (N)-L1-L2-L3

$U_N = 500V$   
terminals (N)-L1-L2-L3

$U_N = 400/230V$   
terminals (N)-L1-L2-L3

$U_N = 400/230V$   
terminals (N)-L1-L2-L3

$U_N = 400/230V$   
terminals (N)-L1-L2-L3

Controls

ASYM • max • min •  
Delay • Function

ASYM • max • min •  
Delay • Function

ASYM • max • min •  
Delay • Function

ASYM • max • min •  
Delay • Function

ASYM • max • min •  
Delay • Function

Indicators (LEDs)

ASYM • max • min • SEQ  
• R

ASYM • max • min • SEQ  
• R

ASYM • max • min • SEQ  
• R

ASYM • max • min • SEQ  
• R

ASYM • max • min • SEQ  
• R

Functions

UNDER  
UNDER+SEQ  
WIN  
WIN+SEQ  
UNDER+LATCH  
UNDER+SEQ+LATCH  
WIN+LATCH  
WIN+SEQ+LATCH

UNDER  
UNDER+SEQ  
WIN  
WIN+SEQ  
UNDER+LATCH  
UNDER+SEQ+LATCH  
WIN+LATCH  
WIN+SEQ+LATCH

UNDER  
UNDER+SEQ  
WIN  
WIN+SEQ

UNDER  
UNDER+SEQ  
WIN  
WIN+SEQ

UNDER  
UNDER+SEQ  
WIN  
WIN+SEQ

Asymmetry

5% to 25% • Off

5% to 25% • Off

5% to 25% • Off

5% to 25% • Off

5% to 25% • Off

Switching threshold max.

-20% to 30% from  $U_N$

-20% to 30% from  $U_N$

-20% to 30% from  $U_N$

-20% to 30% from  $U_N$

-20% to 30% from  $U_N$

Switching threshold min.

-30% to 20% from  $U_N$

-30% to 20% from  $U_N$

-30% to 20% from  $U_N$

-30% to 20% from  $U_N$

-30% to 20% from  $U_N$

Tripping delay

0,1s to 10s

0,1s to 10s

0,1s to 10s

0,1s to 10s

0,1s to 10s

Start-up suppression time

-

-

-

-

-

Fault latch

selectable

selectable

-

-

-

Supply

PowerModule TR3  
terminals A1-A2

PowerModule TR3  
terminals A1-A2

24 to 240V AC/DC  
terminals A1-A2

PowerModule TR2  
terminals A1-A2

PowerModule TR2  
terminals A1-A2

Output

2 CO contacts; 250V,  
5AAC

2 CO contacts; 250V,  
5AAC

2 CO contacts; 250V,  
5AAC

2 CO contacts; 250V,  
5AAC

1 CO contact; 250V,  
5AAC

Width

45mm

45mm

22,5mm

22,5mm

22,5mm

Certificates

CE • cULus • GOST

CE • cULus • GOST

CE • cULus • GOST

CE • cULus • GOST

CE • cULus • GOST

Mechanical design

Self-extinguishing plastic housing, IP rating IP40 • Mounted on DIN-Rail TS 35 in accordance with EN 60715 • Mounting position any • Shockproof terminal connection according to VBG 4 (PZ1 required), IP rating IP20 • Tightening torque max. 1Nm

Terminal capacity

1 x 0,5 to 2,5mm<sup>2</sup> with/without multicore cable end • 1 x 4mm<sup>2</sup> without multicore cable end • 2 x 0,5 to 1,5mm<sup>2</sup> with/without multicore cable end • 2 x 2,5mm<sup>2</sup> flexible without multicore cable end

Ambient conditions

Ambient temperature: -25 to 55°C (in accordance with IEC 60068-1); -25 to 40°C (in accordance with UL 508) • Storage temperature: -25 to +70°C • Transport temperature: -25 to +70°C • relative humidity: 15% to 85% (in accordance with IEC 60721-3-3 class 3K3) • Pollution degree: 3 (in accordance with IEC 60664-1) • Vibration resistance: 10 to 55Hz 0,35mm (in accordance with IEC 60068-2-6) • Shock resistance: 15g 11ms (in accordance with IEC 60068-2-27)

Accessories

PowerModules TR2 (12 - 400V AC) and TR3 (12 - 500V AC) • sealable intervention protection shield FA-G2 • DC power supply SNT2 24VDC

UNDER	Undervoltage monitoring
UNDER+SEQ	Undervoltage monitoring and monitoring of phase sequence
WIN	Monitoring the window between Min and Max
WIN+SEQ	Monitoring the window between Min and Max and monitoring of phase sequence
UNDER+Latch	Undervoltage monitoring with fault latch
UNDER+SEQ+Latch	Undervoltage monitoring and monitoring of phase sequence with fault latch
WIN+Latch	WIN with fault latch
WIN+SEQ+Latch	Monitoring the window between Min and Max and monitoring of phase sequence with fault latch

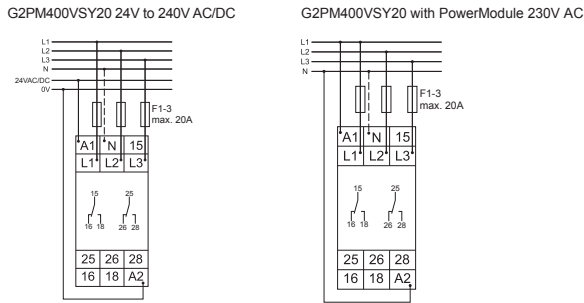
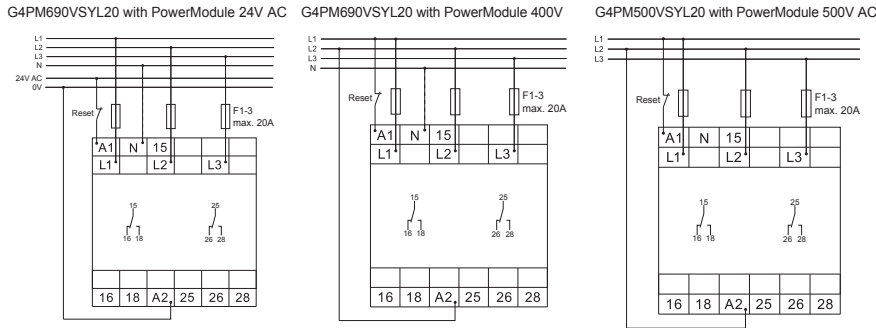

Width 22,5mm

Width 45mm

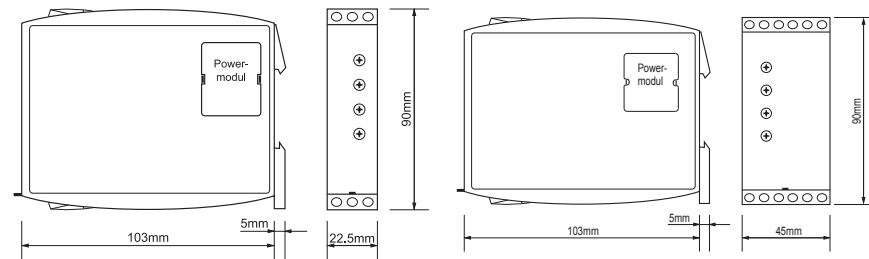

Functions



Sensing & Monitoring Relays Series GAMMA

WatchDog



Voltage monitoring in 3-phase mains

- Multifunction (G2PM); Windowfunction (G2PW)
- Monitoring of phase sequence and phase failure (G2PM)
- Asymmetry detection switchable (G2PM)
- Connection of neutral wire optional (G2PM)
- Detection of loss of neutral wire (G2PM)
- Supply voltage selectable via PowerModules or by zoom voltage 24-240V
- 1 CO contact; 2 CO contacts
- Width 22,5mm
- Industrial design

Connections

types

G2PM230VSY20 24-240V	G2PM230VSY10	G2PM115VSY20 24-240V	G2PM115VSY10	G2PW400V10
-------------------------	--------------	-------------------------	--------------	------------



Art.No. (PQ1)  
Art.No. (PQ10)  
EAN13-Code  
Measured variable

2390512	2390503	2390506	2390502	2390501
-	-	-	-	-
900866200287	900866200280	900866200516	900866200279	900866200277

Connections

Measured range

3(N)~ AC Sinus (48 to 63Hz) $U_N = 230/132V$ terminals (N)-L1-L2-L3	3(N)~ AC Sinus (48 to 63Hz) $U_N = 230/132V$ terminals (N)-L1-L2-L3	3(N)~ AC Sinus (48 to 63Hz) $U_N = 115/66V$ terminals (N)-L1-L2-L3	3(N)~ AC Sinus (48 to 63Hz) $U_N = 115/66V$ terminals (N)-L1-L2-L3	3~ AC Sinus (48 to 63Hz) $U_N = 400/230V$ terminals L1-L2-L3
--	--	---	---	---

Controls

ASYM • max • min • Delay • Function	ASYM • max • min • Delay • Function	ASYM • max • min • Delay • Function	ASYM • max • min • Delay • Function	max • min • Delay
-------------------------------------	-------------------------------------	-------------------------------------	-------------------------------------	-------------------

Indicators (LEDs)

ASYM • max • min • SEQ • R	ASYM • max • min • SEQ • R	ASYM • max • min • SEQ • R	ASYM • max • min • SEQ • R	U • max • min • R
----------------------------	----------------------------	----------------------------	----------------------------	-------------------

Functions

UNDER UNDER+SEQ WIN WIN+SEQ	UNDER UNDER+SEQ WIN WIN+SEQ	UNDER UNDER+SEQ WIN WIN+SEQ	UNDER UNDER+SEQ WIN WIN+SEQ	WIN
--------------------------------------	--------------------------------------	--------------------------------------	--------------------------------------	-----

Asymmetry

5% to 25% • Off	5% to 25% • Off	5% to 25%	5% to 25% • Off	-
-----------------	-----------------	-----------	-----------------	---

Switching threshold max.

-20% to 30% from $U_N$	-20% to 30% from $U_N$	-20% to 30% from $U_N$	-20% to 30% from $U_N$	-20% to 30% from $U_N$
------------------------	------------------------	------------------------	------------------------	------------------------

Switching threshold min.

-30% to 20% from $U_N$	-30% to 20% from $U_N$	-30% to 20% from $U_N$	-30% to 20% from $U_N$	-30% to 20% from $U_N$
------------------------	------------------------	------------------------	------------------------	------------------------

Tripping delay

0,1s to 10s	0,1s to 10s	0,1s to 10s	0,1s to 10s	0,2s to 10s
-------------	-------------	-------------	-------------	-------------

Start-up suppression time

-	-	-	-	-
---	---	---	---	---

Fault latch

-	-	-	-	-
---	---	---	---	---

Supply

24 to 240V AC/DC terminals A1-A2	PowerModule TR2 or SNT2 terminals A1-A2	24 to 240V AC/DC terminals A1-A2	PowerModule TR2 or SNT2 terminals A1-A2	PowerModule TR2 or SNT2 terminals A1-A2
----------------------------------	---	----------------------------------	---	---

Output

2 CO contacts 250V, 5A AC	1 CO contact 250V, 5A AC	2 CO contacts 250V, 5A AC	1 CO contact 250V, 5A AC	1 CO contact 250V, 5A AC
------------------------------	-----------------------------	------------------------------	-----------------------------	-----------------------------

Width

22,5mm	22,5mm	22,5mm	22,5mm	22,5mm
--------	--------	--------	--------	--------

Certificates

CE • cULus • GOST	CE • cULus • GOST	CE • cULus • GOST	CE • cULus • GOST	CE • cULus • GOST
-------------------	-------------------	-------------------	-------------------	-------------------

Mechanical design

Self-extinguishing plastic housing, IP rating IP40 • Mounted on DIN-Rail TS 35 in accordance with EN 60715 • Mounting position any • Shockproof terminal connection according to VBG 4 (PZ1 required) • IP rating IP20 • Tightening torque max. 1Nm

Terminal capacity

1 x 0,5 to 2,5mm<sup>2</sup> with/without multicore cable end • 1 x 4mm<sup>2</sup> without multicore cable end • 2 x 0,5 to 1,5mm<sup>2</sup> with/without multicore cable end • 2 x 2,5mm<sup>2</sup> flexible without multicore cable end

Ambient conditions

Ambient temperature: -25 to 55°C (in accordance with IEC 60068-1); -25 to 40°C (in accordance with UL 508) • Storage temperature: -25 to +70°C • Transport temperature: -25 to +70°C • relative humidity: 15% to 85% (in accordance with IEC 60721-3-3 class 3K3) • Pollution degree: 3 (in accordance with IEC 60664-1) • Vibration resistance: 10 to 55Hz 0,35mm (in accordance with IEC 60068-2-6) • Shock resistance: 15g 11ms (in accordance with IEC 60068-2-27)

Accessories

PowerModule TR2 (12 - 440V AC) • DC power supply SNT2 24V DC • sealable intervention protection shield FA-G2

UNDER	Undervoltage monitoring
UNDER+SEQ	Undervoltage monitoring and monitoring of phase sequence
WIN	Monitoring the window between Min and Max
WIN+SEQ	Monitoring the window between Min and Max and monitoring of phase sequence

G2PM with PowerModule 24V AC

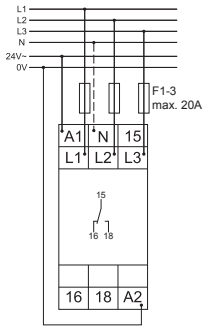

G2PM with PowerModule 230VAC

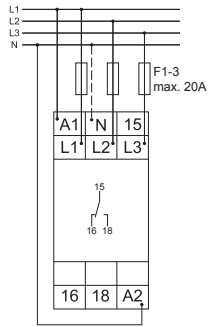

G2PM with PowerModule 400VAC

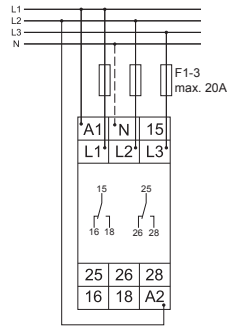

Width 22.5mm

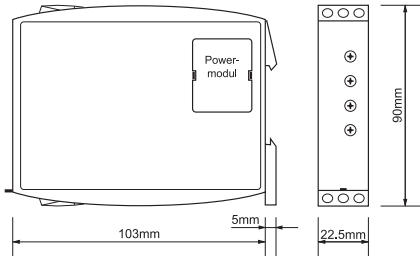

Functions



Sensing & Monitoring Relays Series GAMMA

WatchDog



Voltage monitoring in 3-phase mains

- Multifunction (G2PM); Windowfunction
- Monitoring of phase sequence and phase failure
- Asymmetry detection switchable
- Connection of neutral wire optional
- Detection of loss of neutral wire
- Supply voltage selectable via PowerModules or by zoom voltage 24-240V
- 1 CO contact; 2 CO contacts
- Width 22,5mm
- Industrial design

Connections

types

G2PU690VS20

G2PU400VSY10  
230V AC



Art.No. (PQ1)  
Art.No. (PQ10)  
EAN13-Code

Measured variable

Measured range

Controls

Indicators (LEDs)

Functions

Asymmetry

Switching threshold max.

Switching threshold min.

Tripping delay

Start-up suppression time

Fault latch

Supply

Output

Width

Certificates

Mechanical design

Terminal capacity

Ambient conditions

Accessories

2390507

-

9008662006454

3~  
AC Sinus (48 bis 63Hz)  
208V to 690V  
terminals L1-L2-L3

min • Delay

U • min • SEQ • R

UNDER+SEQ

fixeded, 25%

-

180V to 690V

0,1s to 10s

-

-

= measuring voltage  
3~ 177V to 794V  
Terminals L1-L2-L3

2 CO contacts  
250V, 5A AC

22,5mm

CE • GOST

Self-extinguishing plastic housing, IP rating IP40 • Mounted on DIN-Rail TS 35 in accordance with EN 60715 • Mounting position any • Shockproof terminal connection according to VBG 4 (PZ1 required) • IP rating IP20 • Tightening torque max. 1Nm

1 x 0,5 to 2,5mm<sup>2</sup> with/without multicore cable end • 1 x 4mm<sup>2</sup> without multicore cable end • 2 x 0,5 to 1,5mm<sup>2</sup> with/without multicore cable end • 2 x 2,5mm<sup>2</sup> flexible without multicore cable end

Ambient temperature: -25 to 55°C (in accordance with IEC 60068-1); -25 to 40°C (in accordance with UL 508) • Storage temperature: -25 to +70°C • Transport temperature: -25 to +70°C • relative humidity: 15% to 85% (in accordance with IEC 60721-3-3 class 3K3) • Pollution degree: 3 (in accordance with IEC 60664-1) • Vibration resistance: 10 to 55Hz 0,35mm (in accordance with IEC 60068-2-6) • Shock resistance: 15g 11ms (in accordance with IEC 60068-2-27)

Sealable intervention protection shield FA-G2

2390511B

-

9008662006652

3(N)~  
AC Sinus (48 to 63Hz)  
U<sub>N</sub> = 400/230V  
terminals (N)-L1-L2-L3

ASYM • max • min

ASYM • max • min • SEQ • R

UNDER+SEQ

5% to 25%

-20% to +30% from U<sub>N</sub>

-30% to +20% from U<sub>N</sub>

-

-

-

230V AC  
terminals A1-A2

1 CO contact  
250V, 5A AC

22,5mm

CE • cULus • GOST



G2PU400VSY10, supply voltage 230V AC

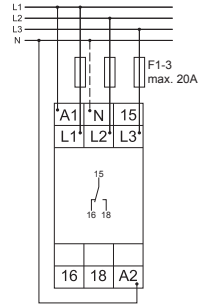

G2PU690VS20

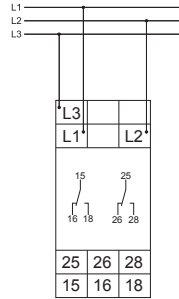

Width 22.5mm

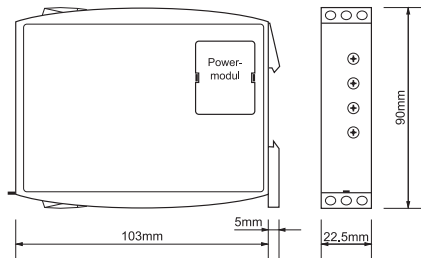

Functions



Sensing & Monitoring Relays Series GAMMA

WatchDog



Voltage monitoring in 3-phase mains

- Multifunction
- Monitors phase to neutral voltages
- Connection of neutral wire necessary
- Fault latch
- Supply voltage selectable via PowerModules or DC power supply
- 2 CO contacts
- Width 22,5mm
- Industrial design

Connections

types

G2YM400VL20



Art.No. (PQ1)  
Art.No. (PQ10)  
EAN13-Code  
Measured variable

Measured range

Controls

Indicators (LEDs)

Functions

Asymmetry

Switching threshold max.

Switching threshold min.

Tripping delay

Start-up suppression time

Fault latch

Supply

Output

Width

Certificates

Mechanical design

Terminal capacity

Ambient conditions

Accessories

2390508

-

900866200285

3N~  
AC Sinus (16 to 400Hz)

$U_N = 400/230V$   
terminals N-L1-L2-L3

max • min • Delay • Function

U • max • min • R

OVER  
OVER+LATCH  
UNDER  
UNDER+LATCH  
WIN  
WIN+LATCH

-

-20% to 30% from  $U_N$

-30% to 20% from  $U_N$

0,1s to 10s

-

selectable

PowerModule TR2 or SNT2  
terminals A1-A2

2 CO contacts  
250V, 5AAC

22,5mm

CE • cULus • GOST

Self-extinguishing plastic housing, IP rating IP40 • Mounted on DIN-Rail TS 35 in accordance with EN 60715 • Mounting position any • Shockproof terminal connection according to VBG 4 (PZ1 required) • IP rating IP20 • Tightening torque max. 1Nm

1 x 0,5 to 2,5mm<sup>2</sup> with/without multicore cable end • 1 x 4mm<sup>2</sup> without multicore cable end • 2 x 0,5 to 1,5mm<sup>2</sup> with/without multicore cable end • 2 x 2,5mm<sup>2</sup> flexible without multicore cable end

Ambient temperature: -25 to 55°C (in accordance with IEC 60068-1); -25 to 40°C (in accordance with UL 508) • Storage temperature: -25 to +70°C • Transport temperature: -25 to +70°C • relative humidity: 15% to 85% (in accordance with IEC 60721-3-3 class 3K3) • Pollution degree: 3 (in accordance with IEC 60664-1) • Vibration resistance: 10 to 55Hz 0,35mm (in accordance with IEC 60068-2-6) • Shock resistance: 15g 11ms (in accordance with IEC 60068-2-27)

PowerModulee TR2 (12 to 440V AC) • DC power supply SNT2 24V DC • sealable intervention protection shield FA-G2

OVER	Overvoltage monitoring
OVER+Latch	Overvoltage monitoring with fault latch
UNDER	Undervoltage monitoring
UNDER+Latch	Undervoltage monitoring with fault latch
WIN	Monitoring the window between Min and Max
WIN+Latch	Monitoring the window between Min and Max with fault latch

G2YM400VL20 with PowerModule 24V AC without fault latch

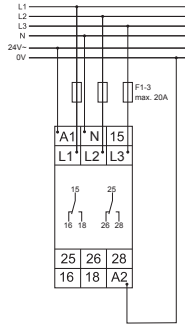

G2YM400VL20 with PowerModule 230V AC with fault latch

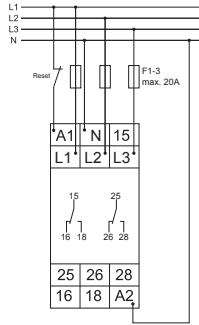

G2YM400VL20 with PowerModule 230V AC without fault latch

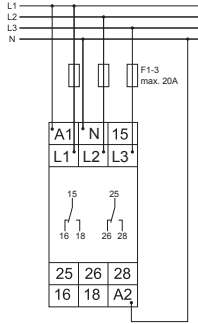

Width 22,5mm

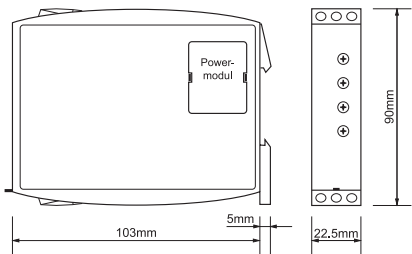

Functions



Sensing & Monitoring Relays Series GAMMA

WatchDog



Voltage monitoring in 3-phase mains

- Monitoring of phase sequence and phase failure
- Detection of reverse voltage
- Connection of neutral wire optional
- Supply voltage = measuring voltage
- 2 CO contacts
- Width 22,5mm
- Industrial design

Connections

types

G2PF400VS02

G2PF230VS02

G2PF115VS02



Art.No. (PQ1)

2390000

2390001

2390002

Art.No. (PQ10)

2390000B

-

-

EAN13-Code

900866200229

900866200232

900866200234

Measured variable

3(N)~  
AC Sinus (48 to 63Hz)  
 $U_N = 400/230V$   
terminals (N)-L1-L2-L3

3(N)~  
AC Sinus (48 to 63Hz)  
 $U_N = 230/132V$   
terminals (N)-L1-L2-L3

3(N)~  
AC Sinus (48 to 63Hz)  
 $U_N = 115/66V$   
terminals (N)-L1-L2-L3

Measured range

Controls

Indicators (LEDs)

Functions

Asymmetry

Switching threshold max.

Switching threshold min.

Tripping delay

Start-up suppression time

Fault latch

Supply

Output

Width

Certificates

Mechanical design

Terminal capacity

Ambient conditions

Accessories

Connections

Art.No. (PQ1)	Art.No. (PQ10)	Art.No. (PQ1)	Art.No. (PQ10)	Art.No. (PQ1)	Art.No. (PQ10)
2390000	2390000B	2390001	-	2390002	-
900866200229	900866200229	900866200232	900866200232	900866200234	900866200234
3(N)~ AC Sinus (48 to 63Hz) $U_N = 400/230V$ terminals (N)-L1-L2-L3	3(N)~ AC Sinus (48 to 63Hz) $U_N = 400/230V$ terminals (N)-L1-L2-L3	3(N)~ AC Sinus (48 to 63Hz) $U_N = 230/132V$ terminals (N)-L1-L2-L3	3(N)~ AC Sinus (48 to 63Hz) $U_N = 230/132V$ terminals (N)-L1-L2-L3	3(N)~ AC Sinus (48 to 63Hz) $U_N = 115/66V$ terminals (N)-L1-L2-L3	3(N)~ AC Sinus (48 to 63Hz) $U_N = 115/66V$ terminals (N)-L1-L2-L3
U • R	U • R	U • R	U • R	U • R	U • R
Monitoring of phase sequence and phase failure	Monitoring of phase sequence and phase failure	Monitoring of phase sequence and phase failure	Monitoring of phase sequence and phase failure	Monitoring of phase sequence and phase failure	Monitoring of phase sequence and phase failure
fixed, typ. 30%	fixed, typ. 30%	fixed, typ. 30%	fixed, typ. 30%	fixed, typ. 30%	fixed, typ. 30%
-	-	-	-	-	-
fixed, max. 350ms	fixed, max. 350ms	fixed, max. 350ms	fixed, max. 350ms	fixed, max. 350ms	fixed, max. 350ms
fixed, max. 500ms	fixed, max. 500ms	fixed, max. 500ms	fixed, max. 500ms	fixed, max. 500ms	fixed, max. 500ms
-	-	-	-	-	-
= measuring voltage 3(N)~ 342 to 457V terminals (N)-L1-L2-L3	= measuring voltage 3(N)~ 342 to 457V terminals (N)-L1-L2-L3	= measuring voltage 3(N)~ 198 to 264V terminals (N)-L1-L2-L3	= measuring voltage 3(N)~ 198 to 264V terminals (N)-L1-L2-L3	= measuring voltage 3(N)~ 99 to 132V terminals (N)-L1-L2-L3	= measuring voltage 3(N)~ 99 to 132V terminals (N)-L1-L2-L3
2 CO contacts 250V, 5A AC	2 CO contacts 250V, 5A AC	2 CO contacts 250V, 5A AC	2 CO contacts 250V, 5A AC	2 CO contacts 250V, 5A AC	2 CO contacts 250V, 5A AC
22,5mm	22,5mm	22,5mm	22,5mm	22,5mm	22,5mm
CE • cULus • GOST	CE • cULus • GOST	CE • cULus • GOST	CE • cULus • GOST	CE • cULus • GOST	CE • cULus • GOST
Self-extinguishing plastic housing, IP rating IP40 • Mounted on DIN-Rail TS 35 in accordance with EN 60715 • Mounting position any • Shockproof terminal connection according to VBG 4 (PZ1 required) • IP rating IP20 • Tightening torque max. 1Nm					
1 x 0,5 to 2,5mm <sup>2</sup> with/without multicore cable end • 1 x 4mm <sup>2</sup> without multicore cable end • 2 x 0,5 to 1,5mm <sup>2</sup> with/without multicore cable end • 2 x 2,5mm <sup>2</sup> flexible without multicore cable end					
Ambient temperature: -25 to 55°C (in accordance with IEC 60068-1); -25 to 40°C (in accordance with UL 508) • Storage temperature: -25 to +70°C • Transport temperature: -25 to +70°C • relative humidity: 15% to 85% (in accordance with IEC 60721-3-3 class 3K3) • Pollution degree: 3 (in accordance with IEC 60664-1) • Vibration resistance: 10 to 55Hz 0,35mm (in accordance with IEC 60068-2-6) • Shock resistance: 15g 11ms (in accordance with IEC 60068-2-27)					
-					

Dimensions

G2PF...S02

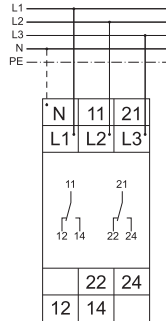

Width 22.5mm

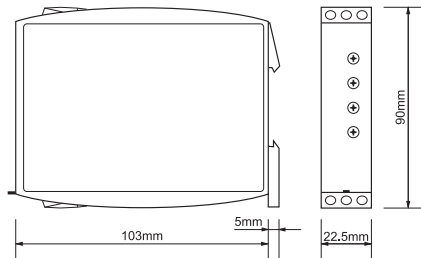

Functions



Sensing & Monitoring Relays Series GAMMA

WatchDog



Frequency monitoring for 50/60Hz networks

- Window function
- Measured voltage 110V to 400V
- Error memory
- Voltage breakdown detection
- Supply voltage 24 to 240V AC/DC
- 2 CO contacts
- Width 22,5mm
- Industrial design

Connections

types

G2FW400VL20 24-240V



Art.No. (PQ1)  
Art.No. (PQ10)  
EAN13-Code  
Measured variable

2390900

-

9008662006607

Frequency, 1-phase terminals F-E

110V to 400V terminals F-E

Start • max • min • Delay • Function

U/t • max • min • UFailure • R

WIN

$F_N = 50\text{Hz}$ : 49, 49.5, 50, 50.5, 51, 52, 53, 55, 57.5, 60Hz  
 $F_N = 60\text{Hz}$ : 59, 59.5, 60, 60.5, 61, 62, 63, 65, 67.5, 70Hz

$F_N = 50\text{Hz}$ : 40, 42.5, 45, 47, 48, 49, 49.5, 50, 50.5, 51Hz  
 $F_N = 60\text{Hz}$ : 50, 52.5, 55, 57, 58, 59, 59.5, 60, 60.5, 61Hz

Measured range

Controls

Indicators (LEDs)

Functions

Switching threshold max.

Switching threshold min.

Tripping delay

Start-up suppression time

Fault latch

Supply

Output

Width

Certificates

Mechanical design

Terminal capacity

Ambient conditions

Accessories

Art.No. (PQ1)	2390900
Art.No. (PQ10)	-
EAN13-Code	9008662006607
Measured variable	Frequency, 1-phase terminals F-E
Measured range	110V to 400V terminals F-E
Controls	Start • max • min • Delay • Function
Indicators (LEDs)	U/t • max • min • UFailure • R
Functions	WIN
Switching threshold max.	$F_N = 50\text{Hz}$ : 49, 49.5, 50, 50.5, 51, 52, 53, 55, 57.5, 60Hz $F_N = 60\text{Hz}$ : 59, 59.5, 60, 60.5, 61, 62, 63, 65, 67.5, 70Hz
Switching threshold min.	$F_N = 50\text{Hz}$ : 40, 42.5, 45, 47, 48, 49, 49.5, 50, 50.5, 51Hz $F_N = 60\text{Hz}$ : 50, 52.5, 55, 57, 58, 59, 59.5, 60, 60.5, 61Hz
Tripping delay	0,1s to 10s
Start-up suppression time	0s to 10s
Fault latch	-
Supply	24 to 240V AC/DC terminals A1-A2
Output	2 CO contacts 250V, 5AAC
Width	22,5mm
Certificates	CE
Mechanical design	Self-extinguishing plastic housing, IP rating IP40 • Mounted on DIN-Rail TS 35 in accordance with EN 60715 • Mounting position any • Shockproof terminal connection according to VBG 4 (PZ1 required) • IP rating IP20 • Tightening torque max. 1Nm
Terminal capacity	1 x 0,5 to 2,5mm <sup>2</sup> with/without multicore cable end • 1 x 4mm <sup>2</sup> without multicore cable end • 2 x 0,5 to 1,5mm <sup>2</sup> with/without multicore cable end • 2 x 2,5mm <sup>2</sup> flexible without multicore cable end
Ambient conditions	Ambient temperature: -25 to 55°C (in accordance with IEC 60068-1); -25 to 40°C (in accordance with UL 508) • Storage temperature: -25 to +70°C • Transport temperature: -25 to +70°C • relative humidity: 15% to 85% (in accordance with IEC 60721-3-3 class 3K3) • Pollution degree: 3 (in accordance with IEC 60664-1) • Vibration resistance: 10 to 55Hz 0,35mm (in accordance with IEC 60068-2-6) • Shock resistance: 15g 11ms (in accordance with IEC 60068-2-27)
Accessories	PowerModule TR2 (12 to 440V AC) • DC power supply SNT2 24V DC • sealable intervention protection shield FA-G2

**G2FW400VL20 24-240V:**

Frequency monitoring for 50/60Hz supply with adjustable thresholds, separately adjustable on delay and trip delay.

**50Hz:**

**WIN:** Window monitoring, monitoring of range...,  $F_N=50\text{Hz}$

**WIN+Latch:** Window monitoring with error memory,  $F_N=50\text{Hz}$

**60Hz:**

**WIN:** Window monitoring, monitoring of range...,  $F_N=60\text{Hz}$

**WIN+Latch:** Window monitoring with error memory,  $F_N=60\text{Hz}$

G2FW400VL20, measured voltage = 400V AC (phase-phase)  
supply voltage 24-240V AC/DC

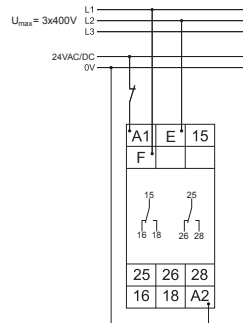

Width 22,5mm

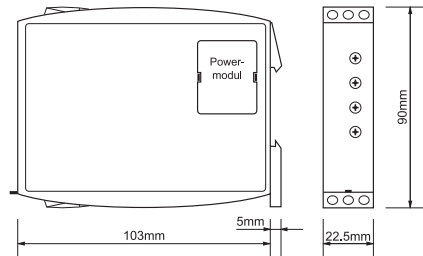

Functions



Sensing & Monitoring Relays Series **GAMMA**

*WatchDog*



Voltage monitoring in 1-phase mains

- Multifunction
- Frequency range 16,6 to 400Hz
- Fault latch
- Supply voltage selectable via PowerModules or by zoom voltage 24 to 240V AC/DC
- 1 CO contact; 2 CO contacts
- Width 22,5mm
- Industrial design

Connections

types

G2UM500VL10 230V

G2UM300VL20  
24-240V AC

G2UM300VL20



Art.No. (PQ1)

2390306A

2390304

2390303

Art.No. (PQ10)

-

-

-

EAN13-Code

900866200262

900866200260

900866200259

Measured variable

Voltage AC/DC  
AC Sinus (16,6 to 400Hz)

Voltage AC/DC  
AC Sinus (16,6 to 400Hz)

Voltage AC/DC  
AC Sinus (16,6 to 400Hz)

Measuring ranges

150V; terminals E-F1(+)  
300V; terminals E-F2(+)  
500V; terminals E-F3(+)

30V; terminals E-F1(+)  
60V; terminals E-F2(+)  
300V; terminals E-F3(+)

30V; terminals E-F1(+)  
60V; terminals E-F2(+)  
300V; terminals E-F3(+)

Controls

Start • max • min • Delay • Function

Start • max • min • Delay • Function

Start • max • min • Delay • Function

Indicators (LEDs)

U/t • max • min • R

U/t • max • min • R

U/t • max • min • R

Functions

OVER  
OVER+LATCH  
UNDER  
UNDER+LATCH  
WIN  
WIN+LATCH

OVER  
OVER+LATCH  
UNDER  
UNDER+LATCH  
WIN  
WIN+LATCH

OVER  
OVER+LATCH  
UNDER  
UNDER+LATCH  
WIN  
WIN+LATCH

Switching threshold max.

10% to 100% from  $U_N$

10% to 100% from  $U_N$

10% to 100% from  $U_N$

Switching threshold min.

5% to 95% from  $U_N$

5% to 95% from  $U_N$

5% to 95% from  $U_N$

Tripping delay

0,1s to 10s

0,1s to 10s

0,1s to 10s

Start-up suppression time

0s to 10s

0s to 10s

0s to 10s

Fault latch

selectable

selectable

selectable

Supply

230V AC  
terminals A1-A2

24 to 240V AC/DC  
terminals A1-A2

PowerModule TR2 or  
SNT2  
terminals A1-A2

Output

1 CO contacts  
250V, 5A AC

2 CO contacts  
250V, 5A AC

2 CO contacts  
250V, 5A AC

Width

22,5mm

22,5mm

22,5mm

Certificates

CE • cULus • GOST

CE • cULus • GOST

CE • cULus • GOST

Mechanical design

Self-extinguishing plastic housing, IP rating IP40 • Mounted on DIN-Rail TS 35 in accordance with EN 60715 • Mounting position any • Shockproof terminal connection according to VBG 4 (PZ1 required), IP rating IP20 • Tightening torque max. 1Nm

Terminal capacity

1 x 0,5 to 2,5mm<sup>2</sup> with/without multicore cable end • 1 x 4mm<sup>2</sup> without multicore cable end • 2 x 0,5 to 1,5mm<sup>2</sup> with/without multicore cable end • 2 x 2,5mm<sup>2</sup> flexible without multicore cable end

Ambient conditions

Ambient temperature: -25 to 55°C (in accordance with IEC 60068-1); -25 to 40°C (in accordance with UL 508) • Storage temperature: -25 to +70°C • Transport temperature: -25 to +70°C • relative humidity: 15% to 85% (in accordance with IEC 60721-3-3 class 3K3) • Pollution degree: 3 (in accordance with IEC 60664-1) • Vibration resistance: 10 to 55Hz, 0,35mm (in accordance with IEC 60068-2-6) • Shock resistance: 15g 11ms (in accordance with IEC 60068-2-27)

Accessories

PowerModule TR2 (12 to 440V AC) • DC power supply SNT2 24V DC • sealable intervention protection shield FA-G2

OVER Overvoltage monitoring  
 UNDER Undervoltage monitoring  
 WIN Monitoring the window between Min and Max

OVER+Latch Overvoltage monitoring with fault latch  
 UNDER+Latch Undervoltage monitoring with fault latch  
 WIN+Latch Monitoring the window between Min and Max with fault latch

G2UM500VL10, measuring range: 300V  
 supply voltage: 230V AC

G2UM300VL20, measuring range: 300V  
 supply voltage: 24-240V AC/DC

G2UM300VL20, measuring range: 30V  
 supply voltage: 24V AC

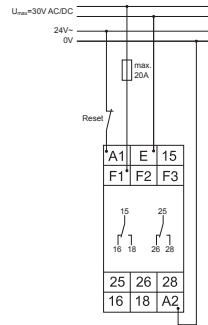
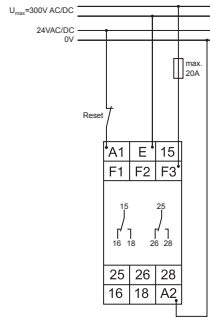
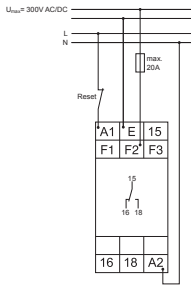

Width 22,5mm

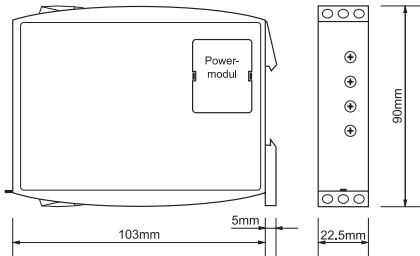

Functions



- Multifunction (G2UM); Windowfunction (G2UW)
- Frequency range 16,6 to 400Hz (G2UM)
- Fault latch (G2UM)
- Supply voltage selectable via PowerModules or by zoom voltage 24 to 240V AC/DC
- 1 CO contact; 2 CO contacts
- Width 22,5mm
- Industrial design

Connections

types

G2UM300VL10

G2UM10VL20  
24-240V AC/DC

G2UW300V10



Art.No. (PQ1)

Art.No. (PQ10)

EAN13-Code

Measured variable

Measuring ranges

Controls

Indicators (LEDs)

Functions

Switching threshold max.

Switching threshold min.

Tripping delay

Start-up suppression time

Fault latch

Supply

Output

Width

Certificates

Mechanical design

Terminal capacity

Ambient conditions

Accessories

Sensing & Monitoring Relays Series GAMMA *WatchDog*



Voltage monitoring in 1-phase mains

	G2UM300VL10	G2UM10VL20 24-240V AC/DC	G2UW300V10
Art.No. (PQ1)	2390300	2390307	2390301
Art.No. (PQ10)	-	-	-
EAN13-Code	900866200256	9008662006089	900866200257
Measured variable	Voltage AC/DC AC Sinus (16 to 400Hz)	Voltage AC/DC AC Sinus (16 to 400Hz)	Voltage AC/DC AC Sinus (48 to 63Hz)
Measuring ranges	30V; terminals E-F1(+) 60V; terminals E-F2(+) 300V; terminals E-F3(+)	60mV; terminals E-F1(+) 150mV; terminals E-F2(+) 10V; terminals E-F3(+)	30V; terminals E-F1(+) 60V; terminals E-F2(+) 300V; terminals E-F3(+)
Controls	Start • max • min • Delay • Function	Start • max • min • Delay • Function	max • min • Delay
Indicators (LEDs)	U/t • max • min • R	U/t • max • min • R	U • max • min • R
Functions	OVER OVER+LATCH UNDER UNDER+LATCH WIN WIN+LATCH	OVER OVER+LATCH UNDER UNDER+LATCH WIN WIN+LATCH	WIN
Switching threshold max.	10% to 100% from U <sub>N</sub>	10% to 100% from U <sub>N</sub>	10% to 100% from U <sub>N</sub>
Switching threshold min.	5% to 95% from U <sub>N</sub>	5% to 95% from U <sub>N</sub>	5% to 95% from U <sub>N</sub>
Tripping delay	0,1s to 10s	0,1s to 10s	0,2s to 10s
Start-up suppression time	0s to 10s	0s to 10s	-
Fault latch	wire link Y1-Y2	selectable	-
Supply	PowerModule TR2 or SNT2 terminals A1-A2	24 to 240V AC/DC terminals A1-A2	PowerModule TR2 or SNT2 terminals A1-A2
Output	1 CO contact 250V, 5AAC	2 CO contacts 250V, 5AAC	1 CO contact 250V, 5AAC
Width	22,5mm	22,5mm	22,5mm
Certificates	CE • cULus • GOST	CE • cULus • GOST	CE • cULus • GOST
Mechanical design	Self-extinguishing plastic housing, IP rating IP40 • Mounted on DIN-Rail TS 35 in accordance with EN 60715 • Mounting position any • Shockproof terminal connection according to VBG 4 (PZ1 required), IP rating IP20 • Tightening torque max. 1Nm		
Terminal capacity	1 x 0,5 to 2,5mm <sup>2</sup> with/without multicore cable end • 1 x 4mm <sup>2</sup> without multicore cable end • 2 x 0,5 to 1,5mm <sup>2</sup> with/without multicore cable end • 2 x 2,5mm <sup>2</sup> flexible without multicore cable end		
Ambient conditions	Ambient temperature: -25 to 55°C (in accordance with IEC 60068-1); -25 to 40°C (in accordance with UL 508) • Storage temperature: -25 to +70°C • Transport temperature: -25 to +70°C • relative humidity: 15% to 85% (in accordance with IEC 60721-3-3 class 3K3) • Pollution degree: 3 (in accordance with IEC 60664-1) • Vibration resistance: 10 to 55Hz 0,35mm (in accordance with IEC 60068-2-6) • Shock resistance: 15g 11ms (in accordance with IEC 60068-2-27)		
Accessories	PowerModulee TR2 (12 to 440V AC) • DC power supply SNT2 24V DC • sealable intervention protection shield FA-G2		

Dimensions

OVER Overvoltage monitoring  
 UNDER UNDERvoltage monitoring  
 WIN Monitoring the window between Min and Max

**G2UM**

Fault latch via wire link Y1-Y2 selectable  
 OVER+Latch Overvoltage monitoring with fault latch  
 UNDER+Latch UNDERvoltage monitoring with fault latch  
 WIN+Latch Monitoring the window between Min and Max with fault latch

G2UM300VL10, measuring range 60V AC/DC, supply voltage: 230V AC  
 G2UM300V10, measuring range 30V AC/DC, supply voltage: 24V AC  
 G2UM10VL20, measuring range: 60mV AC/DC, supply voltage: 24V AC/DC

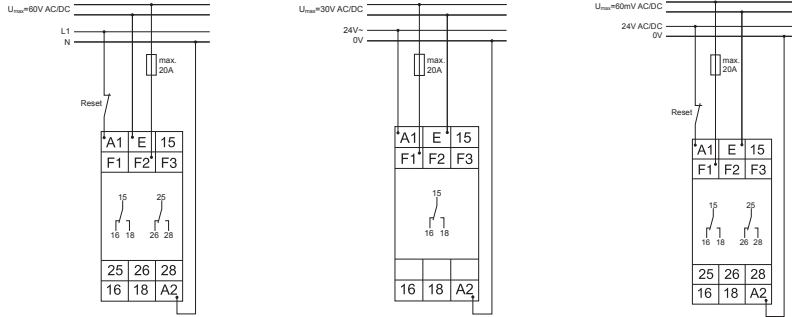

Width 22,5mm

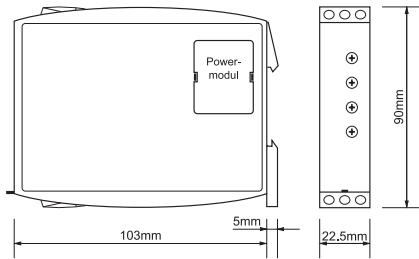

Functions



Sensing & Monitoring Relays Series GAMMA

WatchDog



Current monitoring in 1-phase mains

- Multifunction
- Frequency range 16,6 to 400Hz
- Fault latch
- Supply voltage selectable via PowerModules or by zoom voltage 24 to 240V AC/DC
- 1 CO contact; 2 CO contacts
- Width 22,5mm
- Industrial design

Connections

types

G2IM10AL20  
24-240V

G2IM10AL20

G2IM10AL10

G2IM5AL20  
24-240V



Art.No. (PQ1)

Art.No. (PQ10)

EAN13-Code

Measured variable

Measuring ranges

Controls

Indicators (LEDs)

Functions

Switching threshold max.

Switching threshold min.

Tripping delay

Start-up suppression time

Fault latch

Supply

Output

Width

Certificates

Mechanical design

Terminal capacity

Ambient conditions

Accessories

	G2IM10AL20 24-240V	G2IM10AL20	G2IM10AL10	G2IM5AL20 24-240V
Art.No. (PQ1)	2390410	2390406	2390400	2390411
Art.No. (PQ10)	-	-	-	-
EAN13-Code	900866200273	900866200269	900866200263	900866200274
Measured variable	Current AC/DC AC Sinus (16,6 to 400Hz)	Current AC/DC AC Sinus (16,6 to 400Hz)	Current AC/DC AC Sinus (16,6 to 400Hz)	Current AC/DC AC Sinus (16,6 to 400Hz)
Measuring ranges	100mA AC/DC; terminals K-11(+) 1A AC/DC; terminals K-12(+) 10A AC/DC; terminals K-13(+)	100mA AC/DC; terminals K-11(+) 1A AC/DC; terminals K-12(+) 10A AC/DC; terminals K-13(+)	100mA AC/DC; terminals K-11(+) 1A AC/DC; terminals K-12(+) 10A AC/DC; terminals K-13(+)	20mA AC/DC; terminals K-11(+) 1A AC/DC; terminals K-12(+) 5A AC/DC; terminals K-13(+)
Controls	Start • max • min • Delay • Function	Start • max • min • Delay • Function	Start • max • min • Delay • Function	Start • max • min • Delay • Function
Indicators (LEDs)	U/t • max • min • R	U/t • max • min • R	U/t • max • min • R	U/t • max • min • R
Functions	OVER OVER+LATCH UNDER UNDER+LATCH WIN WIN+LATCH	OVER OVER+LATCH UNDER UNDER+LATCH WIN WIN+LATCH	OVER OVER+LATCH UNDER UNDER + Latch WIN WIN+LATCH	OVER OVER+LATCH UNDER UNDER+LATCH WIN WIN+LATCH
Switching threshold max.	10% to 100% from I <sub>N</sub>	10% to 100% from I <sub>N</sub>	10% to 100% from I <sub>N</sub>	10% to 100% from I <sub>N</sub>
Switching threshold min.	5% to 95% from I <sub>N</sub>	5% to 95% from I <sub>N</sub>	5% to 95% from I <sub>N</sub>	5% to 95% from I <sub>N</sub>
Tripping delay	0,1s to 10s	0,1s to 10s	0,1s to 10s	0,1s to 10s
Start-up suppression time	0s to 10s	0s to 10s	0s to 10s	0s to 10s
Fault latch	selectable	selectable	selectable	selectable
Supply	24 to 240V terminals A1-A2	PowerModule TR2 or SNT2 terminals A1-A2	PowerModule TR2 or SNT2 terminals A1-A2	24 to 240V terminals A1-A2
Output	2 CO contacts 250V, 5A AC	2 CO contacts 250V, 5A AC	1 CO contact 250V, 5A AC	2 CO contacts 250V, 5A AC
Width	22,5mm	22,5mm	22,5mm	22,5mm
Certificates	CE • cULus • GOST	CE • cULus • GOST	CE • cULus • GOST	CE • cULus • GOST
Mechanical design	Self-extinguishing plastic housing, IP rating IP40 • Mounted on DIN-Rail TS 35 in accordance with EN 60715 • Mounting position any • Shockproof terminal connection according to VBG 4 (PZ1 required) • IP rating IP20 • Tightening torque max. 1Nm			
Terminal capacity	1 x 0,5 to 2,5mm <sup>2</sup> with/without multicore cable end • 1 x 4mm <sup>2</sup> without multicore cable end • 2 x 0,5 to 1,5mm <sup>2</sup> with/without multicore cable end • 2 x 2,5mm <sup>2</sup> flexible without multicore cable end			
Ambient conditions	Ambient temperature: -25 to 55°C (in accordance with IEC 60068-1); -25 to 40°C (in accordance with UL 508) • Storage temperature: -25 to +70°C • Transport temperature: -25 to +70°C • relative humidity: 15% to 85% (in accordance with IEC 60721-3-3 class 3K3) • Pollution degree: 3 (in accordance with IEC 60664-1) • Vibration resistance: 10 to 55Hz 0,35mm (in accordance with IEC 60068-2-6) • Shock resistance: 15g 11ms (in accordance with IEC 60068-2-27)			
Accessories	PowerModulee TR2 (12 to 440V AC) • DC power supply SNT2 24V DC • Current Transformers Series DSW and WSW • sealable intervention protection shield FA-G2			

Dimensions



OVER Overcurrent monitoring  
 UNDER Undercurrent monitoring  
 WIN Monitoring the window between Min and Max

OVER+Latch Overcurrent monitoring with fault latch  
 UNDER+Latch Undercurrent monitoring with fault latch  
 WIN+Latch Monitoring the window between Min and Max with fault latch

Measured range 100mA AC/DC,  
 supply voltage: 24V AC/DC

Measured range 1A AC/DC with  
 Powermodule 230V AC

Measured range 5A AC/DC,  
 supply voltage: 24V AC/DC

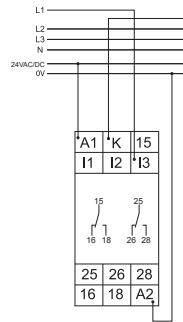
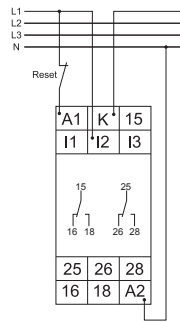
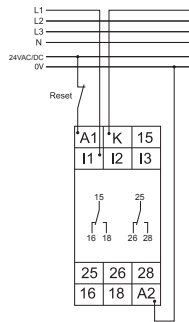

Width 22,5mm

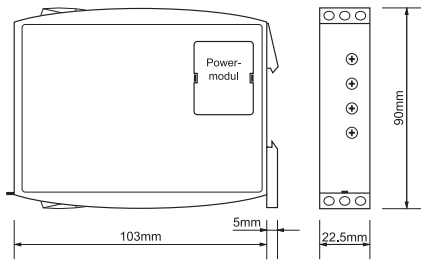

Functions



Sensing & Monitoring Relays Series GAMMA

WatchDog



Current monitoring in 1-phase mains

- Multifunction
- Frequency range 16,6 to 400Hz
- Fault latch
- Supply voltage selectable via PowerModules or by zoom voltage 24-240V
- 1 CO contact; 2 CO contacts
- Width 22,5mm
- Industrial design

Connections

G2IM10AL20 24-240V  
 G2IM10AL20  
 G2IM5AL20 24-240V

types

G2IM5AL20

G2IM5AL10

G2IM2AL20 24-240V



Art.No. (PQ1)

Art.No. (PQ10)

EAN13-Code

Measured variable

Measuring ranges

Controls

Indicators (LEDs)

Functions

Switching threshold max.

Switching threshold min.

Tripping delay

Start-up suppression time

Fault latch

Supply

Output

Width

Certificates

Mechanical design

Terminal capacity

Ambient conditions

Accessories

2390405

-

900866200268

Current AC/DCAC Sinus (16,6 to 400Hz)

20mA AC/DC; terminals K-I1(+)/1A AC/DC; terminals K-I2(+)/5A AC/DC; terminals K-I3(+)

Start • max • min • Delay • Function

U/t • max • min • R

OVER  
 OVER+LATCH  
 UNDER  
 UNDER+LATCH  
 WIN  
 WIN+LATCH

10% to 100% from  $I_N$

5% to 95% from  $I_N$

0,1s to 10s

0s to 10s

selectable

PowerModule TR2 or SNT2 terminals A1-A2

2 CO contacts 250V, 5AAC

22,5mm

CE • cULus • GOST

Self-extinguishing plastic housing, IP rating IP40 • Mounted on DIN-Rail TS 35 in accordance with EN 60715 • Mounting position any • Shockproof terminal connection according to VBG 4 (PZ1 required) • IP rating IP20 • Tightening torque max. 1Nm

1 x 0,5 to 2,5mm<sup>2</sup> with/without multicore cable end • 1 x 4mm<sup>2</sup> without multicore cable end • 2 x 0,5 to 1,5mm<sup>2</sup> with/without multicore cable end • 2 x 2,5mm<sup>2</sup> flexible without multicore cable end

Ambient temperature: -25 to 55°C (in accordance with IEC 60068-1); -25 to 40°C (in accordance with UL 508) • Storage temperature: -25 to +70°C • Transport temperature: -25 to +70°C • relative humidity: 15% to 85% (in accordance with IEC 60721-3-3 class 3K3) • Pollution degree: 3 (in accordance with IEC 60664-1) • Vibration resistance: 10 to 55Hz 0,35mm (in accordance with IEC 60068-2-6) • Shock resistance: 15g 11ms (in accordance with IEC 60068-2-27)

PowerModule TR2 (12 to 440V AC) • DC power supply SNT2 24V DC • Current Transformers Series DSW and WSW • sealable intervention protection shield FA-G2

2390401

-

900866200264

Current AC/DC AC Sinus (16,6 to 400Hz)

20mA AC/DC; terminals K-I1(+)/1A AC/DC; terminals K-I2(+)/5A AC/DC; terminals K-I3(+)

Start • max • min • Delay • Function

U/t • max • min • R

OVER  
 OVER+LATCH  
 UNDER  
 UNDER+LATCH  
 WIN  
 WIN+LATCH

10% to 100% from  $I_N$

5% to 95% from  $I_N$

0,1s to 10s

0s to 10s

selectable

PowerModule TR2 or SNT2 terminals A1-A2

1 CO contact 250V, 5AAC

22,5mm

CE • cULus • GOST

Self-extinguishing plastic housing, IP rating IP40 • Mounted on DIN-Rail TS 35 in accordance with EN 60715 • Mounting position any • Shockproof terminal connection according to VBG 4 (PZ1 required) • IP rating IP20 • Tightening torque max. 1Nm

1 x 0,5 to 2,5mm<sup>2</sup> with/without multicore cable end • 1 x 4mm<sup>2</sup> without multicore cable end • 2 x 0,5 to 1,5mm<sup>2</sup> with/without multicore cable end • 2 x 2,5mm<sup>2</sup> flexible without multicore cable end

Ambient temperature: -25 to 55°C (in accordance with IEC 60068-1); -25 to 40°C (in accordance with UL 508) • Storage temperature: -25 to +70°C • Transport temperature: -25 to +70°C • relative humidity: 15% to 85% (in accordance with IEC 60721-3-3 class 3K3) • Pollution degree: 3 (in accordance with IEC 60664-1) • Vibration resistance: 10 to 55Hz 0,35mm (in accordance with IEC 60068-2-6) • Shock resistance: 15g 11ms (in accordance with IEC 60068-2-27)

PowerModule TR2 (12 to 440V AC) • DC power supply SNT2 24V DC • Current Transformers Series DSW and WSW • sealable intervention protection shield FA-G2

2390417

-

900866200614

Current AC/DC AC Sinus (16,6 to 400Hz)

800mA AC/DC; terminals K-I1(+)/1,5A AC/DC; terminals K-I2(+)/2A AC/DC; terminals K-I3(+)

Start • max • min • Delay • Function

U/t • max • min • R

OVER  
 OVER+LATCH  
 UNDER  
 UNDER+LATCH  
 WIN  
 WIN+LATCH

30% to 100% from  $I_N$

25% to 95% from  $I_N$

0,1s to 10s

0s to 10s

selectable

24-240V terminals A1-A2

1 CO contact 250V, 5AAC

22,5mm

CE • cULus • GOST

Self-extinguishing plastic housing, IP rating IP40 • Mounted on DIN-Rail TS 35 in accordance with EN 60715 • Mounting position any • Shockproof terminal connection according to VBG 4 (PZ1 required) • IP rating IP20 • Tightening torque max. 1Nm

1 x 0,5 to 2,5mm<sup>2</sup> with/without multicore cable end • 1 x 4mm<sup>2</sup> without multicore cable end • 2 x 0,5 to 1,5mm<sup>2</sup> with/without multicore cable end • 2 x 2,5mm<sup>2</sup> flexible without multicore cable end

Ambient temperature: -25 to 55°C (in accordance with IEC 60068-1); -25 to 40°C (in accordance with UL 508) • Storage temperature: -25 to +70°C • Transport temperature: -25 to +70°C • relative humidity: 15% to 85% (in accordance with IEC 60721-3-3 class 3K3) • Pollution degree: 3 (in accordance with IEC 60664-1) • Vibration resistance: 10 to 55Hz 0,35mm (in accordance with IEC 60068-2-6) • Shock resistance: 15g 11ms (in accordance with IEC 60068-2-27)

PowerModule TR2 (12 to 440V AC) • DC power supply SNT2 24V DC • Current Transformers Series DSW and WSW • sealable intervention protection shield FA-G2

OVER Overcurrent monitoring  
 UNDER Undercurrent monitoring  
 WIN Monitoring the window between Min and Max

OVER+Latch Overcurrent monitoring with fault latch  
 UNDER+Latch Undercurrent monitoring with fault latch  
 WIN+Latch Monitoring the window between Min and Max with fault latch

Measuring range 20mA AC/DC, supply voltage: 24V AC/DC

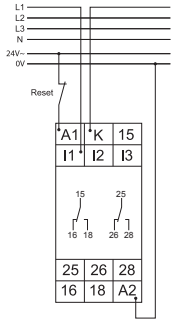

Measuring range 5A AC/DC with Powermodule 400V AC

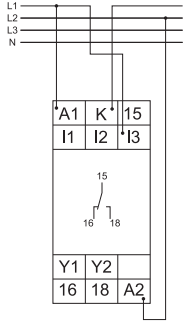

Measuring range 2A AC/DC, supply voltage: 24V AC/DC

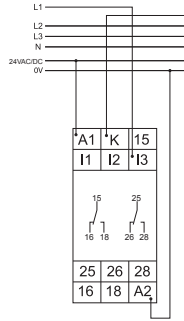

Width 22.5mm

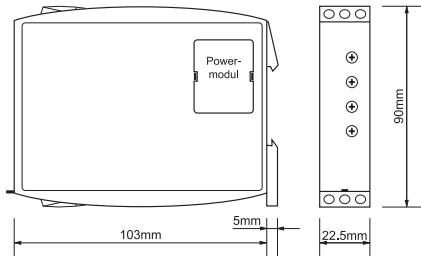

Functions



- Overcurrent monitoring (G2IO)
- UNDERcurrent monitoring (G2IU)
- Supply voltage via PowerModules or DC power supply
- 1 CO contact
- Width 22,5mm
- Industrial design

Sensing & Monitoring Relays Series GAMMA

WatchDog



Current monitoring in 1-phase mains

Connections

G2IM5AL20  
 G2IM5AL10  
 G2IM2AL20 24-240V

types

G2IO10A10

G2IO5A10

G2IU10A10

G2IU5A10



Art.No. (PQ1)

Art.No. (PQ10)

Art.No. (PQ10)

Art.No. (PQ10)

Art.No. (PQ10)

Art.No. (PQ10)

Art.No. (PQ10)

Art.No. (PQ10)

Art.No. (PQ10)

Art.No. (PQ10)

Art.No. (PQ10)

Art.No. (PQ10)

Art.No. (PQ10)

Art.No. (PQ10)

Art.No. (PQ10)

Art.No. (PQ10)

Art.No. (PQ10)

Art.No. (PQ10)

Art.No. (PQ10)

Art.No. (PQ10)

Art.No. (PQ10)

Art.No. (PQ10)

Art.No. (PQ10)

Art.No. (PQ10)

Art.No. (PQ10)

Art.No. (PQ10)

Art.No. (PQ10)

Art.No. (PQ10)

Art.No. (PQ10)

Art.No. (PQ10)

Art.No. (PQ10)

Art.No. (PQ10)

Art.No. (PQ10)

Art.No. (PQ10)

Art.No. (PQ10)

Art.No. (PQ10)

Art.No. (PQ10)

Dimensions

Dimensions

Dimensions

Dimensions

Dimensions

Dimensions

Dimensions

Dimensions

Dimensions

Dimensions

Dimensions

Dimensions

Dimensions

Dimensions

Dimensions

Dimensions

Dimensions

Dimensions

Dimensions

Dimensions

Dimensions

Dimensions

Dimensions

Dimensions

Dimensions

Dimensions

Dimensions

Dimensions

Dimensions

Dimensions

Dimensions

Dimensions

Dimensions

	G2IO10A10	G2IO5A10	G2IU10A10	G2IU5A10
Art.No. (PQ1)	2390408	2390403	2390409	2390404
Art.No. (PQ10)	-	-	-	-
Art.No. (PQ10)	900866200271	900866200266	900866200272	900866200267
Art.No. (PQ10)	Current AC/DC AC Sinus (48 to 63Hz)	Current AC/DC AC Sinus (48 to 63Hz)	Current AC/DC AC Sinus (48 to 63Hz)	Current AC/DC AC Sinus (48 to 63Hz)
Art.No. (PQ10)	100mA AC/DC; terminals K-I1(+) 1A AC/DC; terminals K-I2(+) 10A AC/DC; terminals K-I3(+)	20mA AC/DC; terminals K-I1(+) 1A AC/DC; terminals K-I2(+) 5A AC/DC; terminals K-I3(+)	100mA AC/DC; terminals K-I1(+) 1A AC/DC; terminals K-I2(+) 10A AC/DC; terminals K-I3(+)	20mA AC/DC; terminals K-I1(+) 1A AC/DC; terminals K-I2(+) 5A AC/DC; terminals K-I3(+)
Art.No. (PQ10)	max • min • Delay	max • min • Delay	max • min • Delay	max • min • Delay
Art.No. (PQ10)	U • max • min • R	U • max • min • R	U • max • min • R	U • max • min • R
Art.No. (PQ10)	OVER	OVER	UNDER	UNDER
Art.No. (PQ10)	10% to 100% from I <sub>N</sub>	10% to 100% from I <sub>N</sub>	10% to 100% from I <sub>N</sub>	10% to 100% from I <sub>N</sub>
Art.No. (PQ10)	5% to 95% from I <sub>N</sub>	5% to 95% from I <sub>N</sub>	5% to 95% from I <sub>N</sub>	5% to 95% from I <sub>N</sub>
Art.No. (PQ10)	0,2s to 10s	0,2s to 10s	0,2s to 10s	0,2s to 10s
Art.No. (PQ10)	-	-	-	-
Art.No. (PQ10)	-	-	-	-
Art.No. (PQ10)	PowerModule TR2 or SNT2 terminals A1-A2	PowerModule TR2 or SNT2 terminals A1-A2	PowerModule TR2 or SNT2 terminals A1-A2	PowerModule TR2 or SNT2 terminals A1-A2
Art.No. (PQ10)	1 CO contact 250V, 5A AC	1 CO contact 250V, 5A AC	1 CO contact 250V, 5A AC	1 CO contact 250V, 5A AC
Art.No. (PQ10)	22,5mm	22,5mm	22,5mm	22,5mm
Art.No. (PQ10)	CE • cULus • GOST	CE • cULus • GOST	CE • cULus • GOST	CE • cULus • GOST
Art.No. (PQ10)	Self-extinguishing plastic housing, IP rating IP40 • Mounted on DIN-Rail TS 35 in accordance with EN 60715 • Mounting position any • Shockproof terminal connection according to VBG 4 (PZ1 required) • IP rating IP20 • Tightening torque max. 1Nm			
Art.No. (PQ10)	1 x 0,5 to 2,5mm <sup>2</sup> with/without multicore cable end • 1 x 4mm <sup>2</sup> without multicore cable end • 2 x 0,5 to 1,5mm <sup>2</sup> with/without multicore cable end • 2 x 2,5mm <sup>2</sup> flexible without multicore cable end			
Art.No. (PQ10)	Ambient temperature: -25 to 55°C (in accordance with IEC 60068-1); -25 to 40°C (in accordance with UL 508) • Storage temperature: -25 to +70°C • Transport temperature: -25 to +70°C • relative humidity: 15% to 85% (in accordance with IEC 60721-3-3 class 3K3) • Pollution degree: 3 (in accordance with IEC 60664-1) • Vibration resistance: 10 to 55Hz 0,35mm (in accordance with IEC 60068-2-6) • Shock resistance: 15g 11ms (in accordance with IEC 60068-2-27)			
Art.No. (PQ10)	PowerModules TR2 (12 to 440V AC) • DC power supply SNT2 24V DC • Current Transformers Series DSW and WSW • sealable intervention protection shield FA-G2			

OVER Overcurrent monitoring  
 UNDER Undercurrent monitoring



# Sensing & Monitoring Relays Series GAMMA *WatchDog*



Current monitoring in 3-phase mains

- Multifunction
- Fault latch
- Supply voltage selectable via PowerModules or by zoom voltage 24 to 240V AC/DC
- 2 CO contacts
- Width 22,5mm
- Industrial design

Measured range 20mA with Powermodule 24V AC

Measured range 1A with Powermodule 230V AC

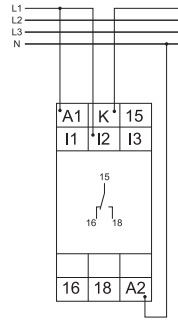
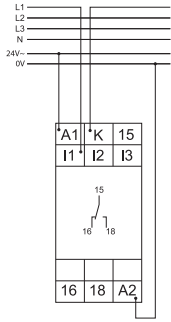

Width 22.5mm

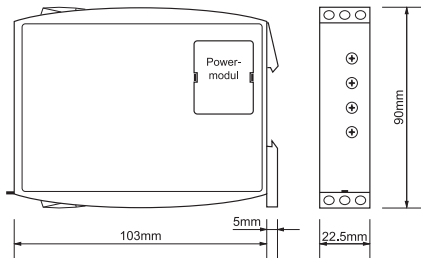

## Functions

## Connections

G2IO5A10  
 G2IU5A10  
 G2IO10A10  
 G2IU10A10

## Dimensions

types

G2JM5AL20 24-240V

G2JM5AL20

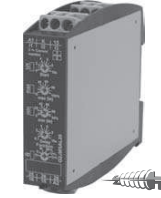

Art.No. (PQ1)  
 Art.No. (PQ10)  
 EAN13-Code  
 Measured variable

Measured range

Controls

Indicators (LEDs)

Functions

Switching threshold max.

Switching threshold min.

Tripping delay

Start-up suppression time

Fault latch

Supply

Output

Width

Certificates

Mechanical design

Terminal capacity

Ambient conditions

Accessories

2390801

-

900866200294

Current 3~  
 AC Sinus (48 to 63Hz)

5A AC  
 terminals K-11, K-12, K-13

Start • max • min • Delay • Function

U/t • max • min • R

OVER  
 OVER+LATCH  
 UNDER  
 UNDER+LATCH  
 WIN  
 WIN+LATCH

10% to 100% from I<sub>N</sub>

5% to 95% from I<sub>N</sub>

0,1s to 10s

0s to 10s

selectable

24 to 240V AC/DC  
 terminals A1-A2

2 CO contacts  
 250V, 5A AC

22,5mm

CE • cULus • GOST

Self-extinguishing plastic housing, IP rating IP40 • Mounted on DIN-Rail TS 35 in accordance with EN 60715 • Mounting position any • Shockproof terminal connection according to VBG 4 (PZ1 required) • IP rating IP20 • Tightening torque max. 1Nm

1 x 0,5 to 2,5mm<sup>2</sup> with/without multicore cable end • 1 x 4mm<sup>2</sup> without multicore cable end • 2 x 0,5 to 1,5mm<sup>2</sup> with/without multicore cable end • 2 x 2,5mm<sup>2</sup> flexible without multicore cable end

Ambient temperature: -25 to 55°C (in accordance with IEC 60068-1); -25 to 40°C (in accordance with UL 508) • Storage temperature: -25 to +70°C • Transport temperature: -25 to +70°C • relative humidity: 15% to 85% (in accordance with IEC 60721-3-3 class 3K3) • Pollution degree: 3 (in accordance with IEC 60664-1) • Vibration resistance: 10 to 55Hz 0,35mm (in accordance with IEC 60068-2-6) • Shock resistance: 15g 11ms (in accordance with IEC 60068-2-27)

PowerModules TR2 (12 to 440V AC) • DC power supply SNT2 24V DC • Current Transformers Series DSW and WSW • sealable intervention protection shield FA-G2

2390800

-

900866200293

Current 3~  
 AC Sinus (48 to 63Hz)

5A AC  
 terminals K-11, K-12, K-13

Start • max • min • Delay • Function

U/t • max • min • R

OVER  
 OVER+LATCH  
 UNDER  
 UNDER+LATCH  
 WIN  
 WIN+LATCH

10% to 100% from I<sub>N</sub>

5% to 95% from I<sub>N</sub>

0,1s to 10s

0s to 10s

selectable

PowerModule TR2 or SNT2  
 terminals A1-A2

2 CO contacts  
 250V, 5A AC

22,5mm

CE • cULus • GOST

OVER	Overcurrent monitoring
OVER+LATCH	Overcurrent monitoring with fault latch
UNDER	Undercurrent monitoring
UNDER+LATCH	Undercurrent monitoring with fault latch
WIN	Monitoring the window between Min and Max
WIN+LATCH	Monitoring the window between Min and Max with fault latch

G2JM5AL20, Supply 230V AC and Current Transformers

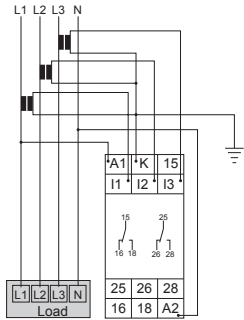

G2JM5AL20, Supply 24-240V AC/DC without fault latch

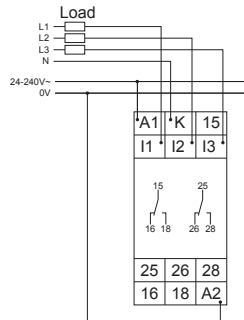

G2JM5AL20, Supply 230V AC and fault latch

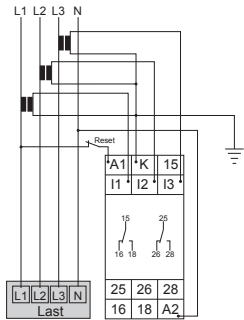

Width 22,5mm

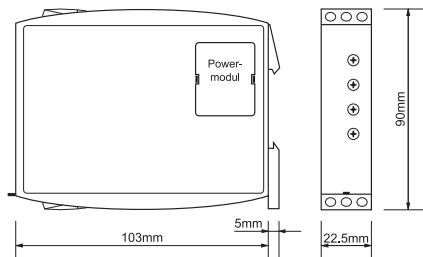

Functions



Sensing & Monitoring Relays Series GAMMA

WatchDog



Temperature monitoring

- Temperature monitoring by PT100 probes (2- and 3-wire connection)
- Multifunction
- Monitoring of short circuit or line break of sensor line
- Fault latch
- Supply voltage by zoom voltage 24 to 240V AC/DC
- 2 CO contacts
- Width 22,5mm
- Industrial design

Connections

types

G2TMPT100L20 24-240V



Art.No. (PQ1)  
Art.No. (PQ10)  
EAN13-Code  
Measured variable

2390904

-

900866200295

Temperature monitoring PT100  
2- and 3-wire connection

-50°C to +200°C  
terminals T1-T2-T3

Start • max • min • Offset • Function

U/t • max • min • Sense • R

Measured range  
Controls  
Indicators (LEDs)  
Functions

OVER  
OVER+LATCH  
UNDER  
UNDER+LATCH  
WIN  
WIN+LATCH

Switching threshold max.  
Switching threshold min.  
Tripping delay  
Start-up suppression time

-45°C to +200°C  
-50°C to 195°C  
-

0min to 30min

Fault latch

selectable

Supply

24 to 240V AC/DC  
terminals A1-A2

Output

2 CO contacts  
250V, 5AAC

Width

22,5mm

Certificates

CE • cULus • GOST

Mechanical design

Self-extinguishing plastic housing, IP rating IP40 • Mounted on DIN-Rail TS 35 in accordance with EN 60715 • Mounting position any • Shockproof terminal connection according to VBG 4 (PZ1 required), IP rating IP20 • Tightening torque max. 1Nm

Terminal capacity

1 x 0,5 to 2,5mm<sup>2</sup> with/without multicore cable end • 1 x 4mm<sup>2</sup> without multicore cable end • 2 x 0,5 to 1,5mm<sup>2</sup> with/without multicore cable end • 2 x 2,5mm<sup>2</sup> flexible without multicore cable end

Ambient conditions

Ambient temperature: -25 to 55°C (in accordance with IEC 60068-1); -25 to 40°C (in accordance with UL 508) • Storage temperature: -25 to +70°C • Transport temperature: -25 to +70°C • relative humidity: 15% to 85% (in accordance with IEC 60721-3-3 class 3K3) • Pollution degree: 3 (in accordance with IEC 60664-1) • Vibration resistance: 10 to 55Hz 0,35mm (in accordance with IEC 60068-2-6) • Shock resistance: 15g 11ms (in accordance with IEC 60068-2-27)

Accessories

Sealable intervention protection shield FA-G2

Connections

Dimensions

OVER	Monitoring of overtemperature
OVER+LATCH	Monitoring of overtemperature with fault latch
UNDER	Monitoring of undertemperature
UNDER+LATCH	Monitoring of undertemperature with fault latch
WIN	Monitoring the window between Min and Max
WIN+LATCH	Monitoring the window between Min and Max with fault latch

2-wire connection, Supply 24V AC/DC and fault latch

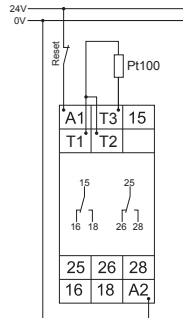

3-wire connection, Supply 230V AC without fault latch

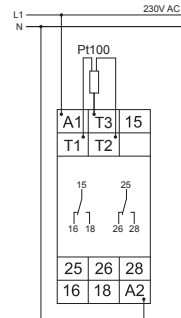

Width 22.5mm

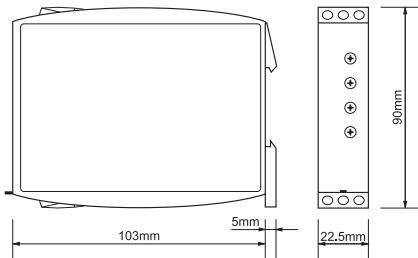

Functions



Sensing & Monitoring Relays Series GAMMA *WatchDog*



Temperature monitoring

- Temperature monitoring of the motor winding in accordance with DIN 44081
- Maximal 6 PTC probes
- Fault latch
- Short circuit monitoring of the PTC Input (G2TFKN02)
- Testfunction with integrated Test/Reset button; possibility for external reset
- Supply voltage selectable via PowerModules or by zoom voltage 24 to 240VAC/DC
- 1 CO contact; 2 CO contacts
- Width 22,5mm
- Industrial design

Connections

types

G2TFKN02  
24-240V

G2TFKN02

G2TF02 24-240V

G2TF02



Art.No. (PQ1)

Art.No. (PQ10)

EAN13-Code

Measured variable

Measured range

Measuring voltage

Controls

Indicators (LEDs)

Functions

Response value

Release value

Short circuit monitoring

Fault latch

Reset

Supply

Output

Width

Certificates

Mechanical design

Terminal capacity

Ambient conditions

Accessories

	G2TFKN02 24-240V	G2TFKN02	G2TF02 24-240V	G2TF02
Art.No. (PQ1)	2390110	2390101	2390111	2390100
Art.No. (PQ10)	-	-	-	-
EAN13-Code	900866200251	900866200237	900866200252	900866200236
Measured variable	PTC (motortemperature) max. 6 PTC probes	PTC (motortemperature) max. 6 PTC probes	PTC (motortemperature) max. 6 PTC probes	PTC (motortemperature) max. 6 PTC probes
Measured range	total resistance cold <1,5kΩ terminals T1-T2	total resistance cold <1,5kΩ terminals T1-T2	total resistance cold <1,5kΩ terminals T1-T2	total resistance cold <1,5kΩ terminals T1-T2
Measuring voltage	<2,5V DC at R ≤4,0kΩ (DINVDE 0660 part 302)	<2,5V DC at R ≤4,0kΩ (DINVDE 0660 part 302)	<2,5V DC at R ≤4,0kΩ (DINVDE 0660 part 302)	<2,5V DC at R ≤4,0kΩ (DINVDE 0660 part 302)
Controls	Test/Reset button • Function	Test/Reset button • Function	Test/Reset button	Test/Reset button
Indicators (LEDs)	U • Failure • R	U • Failure • R	U • Failure	U • Failure
Functions	Overtemperature selectable functions: +K (short circuit monitoring) +N (remanent latch function) +K+N (short circuit monitoring and remanent latch function)	Overtemperature selectable functions: +K (short circuit monitoring) +N (remanent latch function) +K+N (short circuit monitoring and remanent latch function)	Overtemperature	Overtemperature
Response value	3,6kΩ	3,6kΩ	3,6kΩ	3,6kΩ
Release value	1,8kΩ	1,8kΩ	1,8kΩ	1,8kΩ
Short circuit monitoring	<20Ω	<20Ω	-	-
Fault latch	yes (auto)	yes (auto)	yes (auto)	yes (auto)
Reset	internal or external terminals R-T2	internal or external terminals R-T2	internal or external terminals R-T2	internal or external terminals R-T2
Supply	24 to 240V AC/DC terminals A1-A2	PowerModule TR2 or SNT2 terminals A1-A2	24-240V AC/DC terminals A1-A2	PowerModule TR2 or SNT2 terminals A1-A2
Output	2 CO contacts 250V, 5AAC	2 CO contacts 250V, 5AAC	2 CO contacts 250V, 5AAC	2 CO contacts 250V, 5AAC
Width	22,5mm	22,5mm	22,5mm	22,5mm
Certificates	CE • cULus • GOST	CE • cULus • GOST	CE • cULus • GOST	CE • cULus • GOST
Mechanical design	Self-extinguishing plastic housing, IP rating IP40 • Mounted on DIN-Rail TS 35 in accordance with EN 60715 • Mounting position any • Shockproof terminal connection according to VBG 4 (PZ1 required) • IP rating IP20 • Tightening torque max. 1Nm			
Terminal capacity	1 x 0,5 to 2,5mm <sup>2</sup> with/without multicore cable end • 1 x 4mm <sup>2</sup> without multicore cable end • 2 x 0,5 to 1,5mm <sup>2</sup> with/without multicore cable end • 2 x 2,5mm <sup>2</sup> flexible without multicore cable end			
Ambient conditions	Ambient temperature: -25 to 55°C (in accordance with IEC 60068-1); -25 to 40°C (in accordance with UL 508) • Storage temperature: -25 to +70°C • Transport temperature: -25 to +70°C • relative humidity: 15% to 85% (in accordance with IEC 60721-3-3 class 3K3) • Pollution degree: 3 (in accordance with IEC 60664-1) • Vibration resistance: 10 to 55Hz/0,35mm (in accordance with IEC 60068-2-6) • Shock resistance: 15g 11ms (in accordance with IEC 60068-2-27)			
Accessories	PowerModules TR2 (12 to 440V AC) • DC power supply SNT2 24V DC • sealable intervention protection shield FA-G2			

Temperature monitoring of the motor winding (max. 6 PTC) with fault latch, for temperature probes in accordance with DIN 44081, test function with integrated test/reset key and the following additional functions (G2TFKN02):

- Off Basic function
- +K Short circuit monitoring of thermistor line
- +N Zero-voltage latch
- +K+N Short circuit monitoring and zero-voltage latch

G2TF01

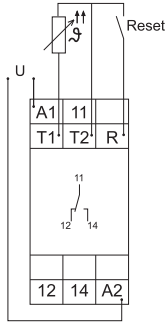

automatic reset by wire link R-T2

Width 22.5mm

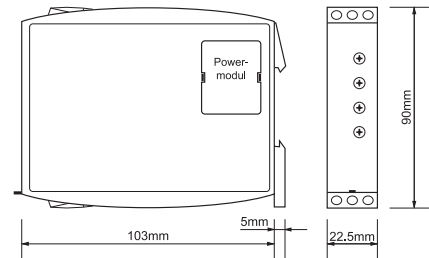

G2TFKN02

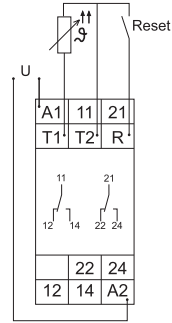

automatic reset by wire link R-T2

Functions



Sensing & Monitoring Relays Series GAMMA

WatchDog



Temperature monitoring

- Temperature monitoring of the motor winding in accordance with DIN 44081
- Maximal 6 PTC probes
- Fault latch
- Testfunction with integrated Test/Reset button
- Possibility for external reset
- Supply voltage selectable via PowerModules or by zoom voltage 24 to 240V AC/DC
- 1 CO contact; 2 CO contacts
- Width 22,5mm
- Industrial design

Connections

types

G2TF02 230V AC

G2TF02 110V AC

G2TF01

G2TF01 230V AC



Art.No. (PQ1)

2390104

2390109

2390103

2390102

Art.No. (PQ10)

-

-

-

2390102A

EAN13-Code

900866200241

900866200249

900866200240

900866200238

Measured variable

PTC (motortemperature)  
max. 6 PTC probes

PTC (motortemperature)  
max. 6 PTC probes

PTC (motortemperature)  
max. 6 PTC probes

PTC (motortemperature)  
max. 6 PTC probes

Measured range

total resistance cold <1,5kΩ  
terminals T1-T2

total resistance cold <1,5kΩ  
terminals T1-T2

total resistance cold <1,5kΩ  
terminals T1-T2

total resistance cold <1,5kΩ  
terminals T1-T2

Measuring voltage

≤2,5V DC at R ≤4,0kΩ  
(DINVE 0660 part 302)

≤2,5V DC at R ≤4,0kΩ  
(DINVE 0660 part 302)

≤2,5V DC at R ≤4,0kΩ(DINVE  
0660 Part 302)

≤2,5V DC at R ≤4,0kΩ(DINVE  
0660 Part 302)

Controls

Test/Reset button

Test/Reset button

Test/Reset button

Test/Reset button

Indicators (LEDs)

U • Failure

U • Failure

U • Failure

U • Failure

Functions

Overtemperature

Overtemperature

Overtemperature

Overtemperature

Response value

3,6kΩ

3,6kΩ

3,6kΩ

3,6kΩ

Release value

1,8kΩ

1,8kΩ

1,8kΩ

1,8kΩ

Short circuit monitoring

-

-

-

-

Fault latch

yes (auto)

yes (auto)

yes (auto)

yes (auto)

Reset

internal or external  
terminals R-T2

internal or external  
terminals R-T2

internal or external  
terminals R-T2

internal or external  
terminals R-T2

Supply

230V AC  
terminals A1-A2

110V AC  
terminals A1-A2

PowerModule TR2 or SNT2  
terminals A1-A2

230V AC  
terminals A1-A2

Output

2 CO contacts  
250V, 5A AC

2 CO contacts  
250V, 5A AC

1 CO contact  
250V, 5A AC

1 CO contact  
250V, 5A AC

Width

22,5mm

22,5mm

22,5mm

22,5mm

Certificates

CE • cULus • GOST

CE • cULus • GOST

CE • cULus • GOST

CE • cULus • GOST

Mechanical design

Self-extinguishing plastic housing, IP rating IP40 • Mounted on DIN-Rail TS 35 in accordance with EN 60715 • Mounting position any • Shockproof terminal connection according to VBG 4 (PZ1 required), IP rating IP20 • Tightening torque max. 1Nm

Terminal capacity

1 x 0,5 to 2,5mm<sup>2</sup> with/without multicore cable end • 1 x 4mm<sup>2</sup> without multicore cable end • 2 x 0,5 to 1,5mm<sup>2</sup> with/without multicore cable end • 2 x 2,5mm<sup>2</sup> flexible without multicore cable end

Ambient conditions

Ambient temperature: -25 to 55°C (in accordance with IEC 60068-1); -25 to 40°C (in accordance with UL 508) • Storage temperature: -25 to +70°C • Transport temperature: -25 to +70°C • relative humidity: 15% to 85% (in accordance with IEC 60721-3-3 class 3K3) • Pollution degree: 3 (in accordance with IEC 60664-1) • Vibration resistance: 10 to 55Hz 0,35mm (in accordance with IEC 60068-2-6) • Shock resistance: 15g 11ms (in accordance with IEC 60068-2-27)

Accessories

PowerModulees TR2 (12 to 440V AC) • DC power supply SNT2 24V DC • sealable intervention protection shield FA-G2

Dimensions



Temperature monitoring of motor winding (max. 6 PTC) with fault latch for probes in accordance with DIN 44081, testfunction with integrated Test/Reset button.

G2TF02

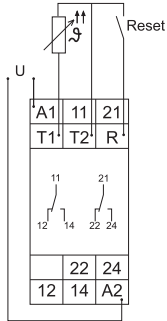

automatic reset by wire link R-T2

Width 22.5mm

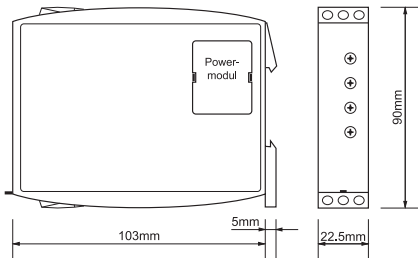

Functions



## Sensing & Monitoring Relays Series GAMMA

WatchDog



Level monitoring

- Level monitoring of conductive substances
- Pump up or minimum monitoring
- Pump down or maximum monitoring
- Secure galvanic separation of measuring circuit
- 2 CO contacts
- Width 22,5mm
- Industrial design

Connections

types

G2LM20 24V AC

G2LM20 110V AC

G2LM20 230V AC



Art.No. (PQ1)

2390201

2390202

2390200

Art.No. (PQ10)

-

-

-

EAN13-Code

900866200254

900866200255

900866200253

Measured variable

level with  
conductive probe

level with  
conductive probe

level with  
conductive probe

Measured range

0,25 to 100kΩ

0,25 to 100kΩ

0,25 to 100kΩ

Probe voltage

max. 16V AC

max. 16V AC

max. 16V AC

Probe current

max. 7mA

max. 7mA

max. 7mA

Wiring distance

max. 1000m (adjustment <50%)  
max. 100m (adjustment <100%)  
capacity of cable 100nF/km

max. 1000m (adjustment <50%)  
max. 100m (adjustment <100%)  
capacity of cable 100nF/km

max. 1000m (adjustment <50%)  
max. 100m (adjustment <100%)  
capacity of cable 100nF/km

Control  
Delay on • Delay off • Sensitivity • Function

U • R

Control  
Delay on • Delay off • Sensitivity • Function

U • R

Control  
Delay on • Delay off • Sensitivity • Function

U • R

Indicators (LEDs)

U • R

U • R

U • R

Functions

Pump up  
Pump down

Pump up  
Pump down

Pump up  
Pump down

Trigger level

0,25 to 100 kΩ (Sensitivity)

0,25 to 100 kΩ (Sensitivity)

0,25 to 100 kΩ (Sensitivity)

Tripping delay

0,5s to 10s

0,5s to 10s

0,5s to 10s

Turn-off delay

0,5s to 10s

0,5s to 10s

0,5s to 10s

Supply

24V AC  
terminals A1-A2

110V AC  
terminals A1-A2

230V AC  
terminals A1-A2

Output

2 CO contacts  
250V, 5A AC

2 CO contacts  
250V, 5A AC

2 CO contacts  
250V, 5A AC

Width

22.5mm

22.5mm

22.5mm

Certificates

CE • cULus • GOST

CE • cULus • GOST

CE • cULus • GOST

Mechanical design

Self-extinguishing plastic housing, IP rating IP40 • Mounted on DIN-Rail TS 35 in accordance with EN 60715 • Mounting position any • Shockproof terminal connection according to VBG 4 (PZ1 required) • IP rating IP20 • Tightening torque max. 1Nm

Terminal capacity

1 x 0,5 to 2,5mm<sup>2</sup> with/without multicore cable end • 1 x 4mm<sup>2</sup> without multicore cable end • 2 x 0,5 to 1,5mm<sup>2</sup> with/without multicore cable end • 2 x 2,5mm<sup>2</sup> flexible without multicore cable end

Ambient conditions

Ambient temperature: -25 to 55°C (in accordance with IEC 60068-1); -25 to 40°C (in accordance with UL 508) • Storage temperature: -25 to +70°C • Transport temperature: -25 to +70°C • relative humidity: 15% to 85% (in accordance with IEC 60721-3-3 class 3K3) • Pollution degree: 3 (in accordance with IEC 60664-1) • Vibration resistance: 10 to 55Hz 0,35mm (in accordance with IEC 60068-2-6) • Shock resistance: 15g 11ms (in accordance with IEC 60068-2-27)

Accessories

conductive probes (types SK1, SK2, SK3) • sealable intervention protection shield FA-G2

Dimensions

Level monitoring of conductive substances, timing for tripping delay and turn-off delay separately adjustable and the following functions:

- Pump up
- Pump down
- Pump up or minimum monitoring
- Pump down or maximum monitoring

G2LM20

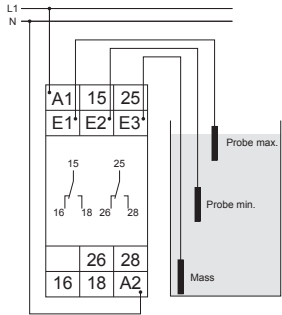

Width 22.5mm

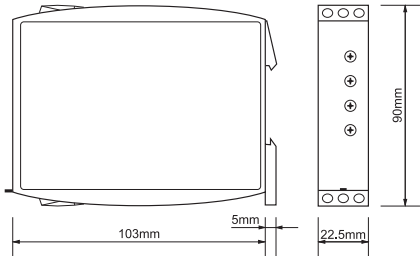

Functions



## Sensing & Monitoring Relays Series TREND

Voltage monitoring in 3-phase mains



- Windowfunction (TPW...VN4X)
- Windowfunction with integrated phase sequence monitoring (TPW...VSN4X)
- Connection of neutral wire optional
- Supply voltage selectable via PowerModules or DC power supply
- 1 CO contact
- Width 45mm
- Industrial design

Connections

types

TPW400VSN4X

TPW230VSN4X

TPW115VSN4X

TPW400VN4X



Art.No. (PQ1)

2400008

2401310

2401210

2401410

Art.No. (PQ10)

-

-

-

-

EAN13-Code

900866200298

900866200304

900866200303

900866200305

Measured variable

3(N)~  
AC Sinus (48 to 63Hz)  
 $U_N = 400/230V$   
terminals (N)-L1-L2-L3

3(N)~  
AC Sinus (48 to 63Hz)  
 $U_N = 230/133V$   
terminals (N)-L1-L2-L3

3(N)~  
AC Sinus (48 to 63Hz)  
 $U_N = 115/66V$   
terminals (N)-L1-L2-L3

3(N)~  
AC Sinus (48 to 63Hz)  
 $U_N = 400/230V$   
terminals (N)-L1-L2-L3

Measured range

max • min • Delay ( $t_d$ )  
max • R • min

max • min • Delay ( $t_d$ )  
max • R • min

max • min • Delay ( $t_d$ )  
max • R • min

max • min • Delay ( $t_d$ )  
max • R • min

Controls

Indicators (LEDs)

Functions

Asymmetry

Switching threshold max.

Switching threshold min.

Tripping delay

Start-up suppression time

Fault latch

Supply

Output

Width

Certificates

Mechanical design

Terminal capacity

Ambient conditions

Accessories

2400008

2401310

2401210

2401410

-

-

-

-

900866200298

900866200304

900866200303

900866200305

3(N)~  
AC Sinus (48 to 63Hz)  
 $U_N = 400/230V$   
terminals (N)-L1-L2-L3

3(N)~  
AC Sinus (48 to 63Hz)  
 $U_N = 230/133V$   
terminals (N)-L1-L2-L3

3(N)~  
AC Sinus (48 to 63Hz)  
 $U_N = 115/66V$   
terminals (N)-L1-L2-L3

3(N)~  
AC Sinus (48 to 63Hz)  
 $U_N = 400/230V$   
terminals (N)-L1-L2-L3

max • min • Delay ( $t_d$ )  
max • R • min

max • min • Delay ( $t_d$ )  
max • R • min

max • min • Delay ( $t_d$ )  
max • R • min

max • min • Delay ( $t_d$ )  
max • R • min

WIN+SEQ  
crabwise by  $U_{min}/U_{max}$

WIN+SEQ  
crabwise by  $U_{min}/U_{max}$

WIN+SEQ  
crabwise by  $U_{min}/U_{max}$

WIN  
crabwise by  $U_{min}/U_{max}$

-20% to 30% from  $U_N$

-20% to 30% from  $U_N$

-20% to 30% from  $U_N$

-20% to 30% from  $U_N$

-30% to 20% from  $U_N$

-30% to 20% from  $U_N$

-30% to 20% from  $U_N$

-30% to 20% from  $U_N$

0,1s to 10s

0,1s to 10s

0,1s to 10s

0,1s to 10s

-

-

-

-

-

-

-

-

PowerModule TR2 or SNT2  
terminals A1-A2

PowerModule TR2 or SNT2  
terminals A1-A2

PowerModule TR2 or SNT2  
terminals A1-A2

PowerModule TR2 or SNT2  
terminals A1-A2

1 CO contact  
250V, 5A AC

1 CO contact  
250V, 5A AC

1 CO contact  
250V, 5A AC

1 CO contact  
250V, 5A AC

45mm

45mm

45mm

45mm

CE

CE

CE

CE

Self-extinguishing plastic housing, IP rating IP40 • Mounted on DIN-Rail TS 35 in accordance with EN 60715 • Mounting position any • Shockproof terminal connection according to VBG 4 (PZ1 required) • IP rating IP20 • Tightening torque max. 1Nm

1 x 0,5 to 2,5mm<sup>2</sup> with/without multicore cable end • 1 x 4mm<sup>2</sup> without multicore cable end • 2 x 0,5 to 1,5mm<sup>2</sup> with/without multicore cable end • 2 x 2,5mm<sup>2</sup> flexible without multicore cable end

Ambient temperature: -25 to +55°C (in accordance with IEC 60068-1) • Storage temperature: -25 to +70°C • Transport temperature: -25 to +70°C • relative humidity: 15% to 85% (in accordance with IEC 60721-3-3 class 3K3) • Pollution degree: 3 (in accordance with IEC 60664-1)

PowerModulees TR2 (12 to 440V AC) • DC power supply SNT2 24V DC

Voltage monitoring in 3-phase mains with adjustable setpoints, adjustable tripping delay and phase sequence monitoring.

WIN Monitoring the window between Min and Max  
 WIN+SEQ Monitoring the window between Min and Max and phase sequence monitoring

TPW...N4X; TPW...SN4X

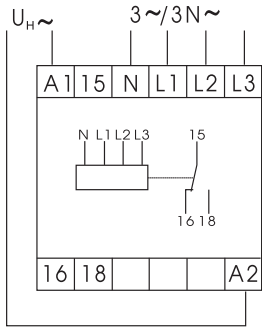

Width 45mm

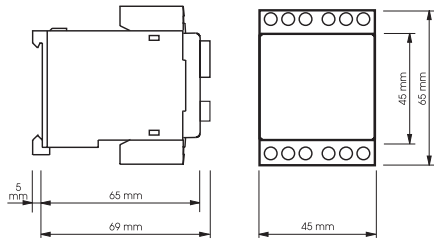

Functions



## Sensing & Monitoring Relays Series TREND

Voltage monitoring in 3-phase mains



- Phase sequence, phase loss and asymmetry monitoring with fixed asymmetry
- No connection of neutral wire required
- 1 CO contact
- Width 45mm
- Industrial design

Connections

types

TPF230VS4X

TPF400VS4X



Art.No. (PQ1)  
 Art.No. (PQ10)  
 EAN13-Code  
 Measured variable

Measured range

Controls  
 Indicators (LEDs)

Functions

Asymmetry

Switching threshold max.

Tripping delay

Start-up suppression time

Fault latch

Supply

Output

Width

Certificates

Mechanical design

Terminal capacity

Ambient conditions

Accessories

Art.No. (PQ1)	2442153	2402058
Art.No. (PQ10)	-	-
EAN13-Code	900866200315	900866200306
Measured variable	3~ AC Sinus (48 to 63Hz)	3~ AC Sinus (48 to 63Hz)
Measured range	$U_N = 230V/132V$ terminals L1-L2-L3	$U_N = 400V/230V$ terminals L1-L2-L3
Controls	-	-
Indicators (LEDs)	R	R
Functions	Monitoring of phase sequence and phase failure	Monitoring of phase sequence and phase failure
Asymmetry	fixed, approx. 10%	fixed, approx. 10%
Switching threshold max.	-	-
Tripping delay	-	-
Start-up suppression time	-	-
Fault latch	-	-
Supply	= measuring voltage; 3~ 230V $\pm 15\%$ terminals L1-L2-L3	= measuring voltage; 3~ 400V $\pm 15\%$ terminals L1-L2-L3
Output	1 CO contact 250V, 5A AC	1 CO contact 250V, 5A AC
Width	45mm	45mm
Certificates	CE	CE
Mechanical design	Self-extinguishing plastic housing, IP rating IP40 • Mounted on DIN-Rail TS 35 in accordance with EN 60715 • Mounting position any • Shockproof terminal connection according to VBG 4 (PZ1 required) • IP rating IP20 • Tightening torque max. 1Nm	
Terminal capacity	1 x 0,5 to 2,5mm <sup>2</sup> with/without multicore cable end • 1 x 4mm <sup>2</sup> without multicore cable end • 2 x 0,5 to 1,5mm <sup>2</sup> with/without multicore cable end • 2 x 2,5mm <sup>2</sup> flexible without multicore cable end	
Ambient conditions	Ambient temperature: -25 to +55°C (in accordance with IEC 60068-1) • Storage temperature: -25 to +70°C • Transport temperature: -25 to +70°C • relative humidity: 15% to 85% (in accordance with IEC 60721-3-3 class 3K3) • Pollution degree: 3 (in accordance with IEC 60664-1)	
Accessories	-	

Phase sequence, phase loss and asymmetry monitoring with fixed asymmetry, no connection of neutral wire necessary.

TPF...S4X

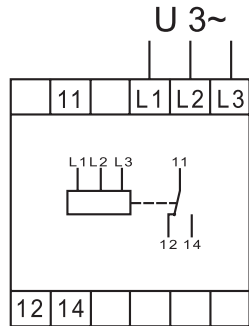

Width 45mm

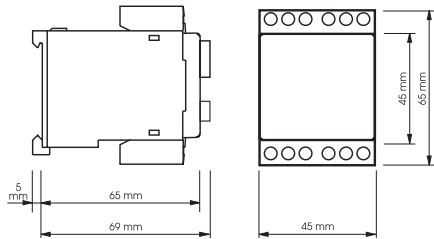

Functions



## Sensing & Monitoring Relays Series TREND

Voltage monitoring in 1-phase mains



- Windowfunction or reverse Windowfunction (TUW4X)
- 1 trigger level with adjustable hysteresis OVER/UNDER (TUH4X)
- Position of output relay selectable
- DIP-Switch for adjusting to AC/DC monitoring and relay position
- Fault latch
- Supply voltage selectable via PowerModules or DC power supply
- 1 CO contact
- Width 45mm
- Industrial design

Connections

types

TUW4X

TUH4X



Art.No. (PQ1)

2420510

2422510

Art.No. (PQ10)

-

-

EAN13-Code

900866200308

900866200309

Measured variable

Voltage AC/DC  
AC Sinus (48 to 63Hz)

Voltage AC/DC  
AC Sinus (48 to 63Hz)

Measuring ranges ( $U_N$ )

24V AC/DC; terminals E1-F1(+)  
115V AC/DC; terminals E1-F2(+)  
230V AC/DC; terminals E1-F3(+)  
440V AC/DC; terminals E2-F3(+)

30V AC/DC; terminals E1-F1(+)  
60V AC/DC; terminals E1-F2(+)  
300V AC/DC; terminals E1-F3(+)  
600V AC/DC; terminals E2-F3(+)

Controls

max • min • Delay ( $t_1$ ) • Start ( $t_2$ ) • AC/DC • REL/REL • Start On/Off

$U_S$  • Hyst • Delay ( $t_1$ ) • Start ( $t_2$ ) • AC/DC • REL/REL • Start On/Off

Indicators (LEDs)

max • R • min

U • R

Functions

WIN • reverse WIN

1 trigger level with hysteresis (OVER/UNDER)

Switching threshold max.

-20% to 30% from  $U_N$

trigger level  $U_S$ : 10% to 100% from  $U_N$

-30% to 20% from  $U_N$

Hysteresis: 5% to 50% from  $U_S$

Tripping delay

$t_1$  = 0,1s to 10s

$t_1$  = 0,1s to 10s

Start-up suppression time

$t_2$  = 0,1s to 10s

$t_2$  = 0,1s to 10s

Fault latch

selectable

selectable

Supply

PowerModule TR2 or SNT2  
terminals A1-A2

PowerModule TR2 or SNT2  
terminals A1-A2

Output

1 CO contact  
250V, 5A AC

1 CO contact  
250V, 5A AC

Width

45mm

45mm

Certificates

CE

CE

Mechanical design

Self-extinguishing plastic housing, IP rating IP40 • Mounted on DIN-Rail TS 35 in accordance with EN 60715 • Mounting position any • Shockproof terminal connection according to VBG 4 (PZ1 required) • IP rating IP20 • Tightening torque max. 1Nm

Terminal capacity

1 x 0,5 to 2,5mm<sup>2</sup> with/without multicore cable end • 1 x 4mm<sup>2</sup> without multicore cable end • 2 x 0,5 to 1,5mm<sup>2</sup> with/without multicore cable end • 2 x 2,5mm<sup>2</sup> flexible without multicore cable end

Ambient conditions

Ambient temperature: -25 to +55°C (in accordance with IEC 60688-1) • Storage temperature: -25 to +70°C • Transport temperature: -25 to +70°C • relative humidity: 15% to 85% (in accordance with IEC 60721-3-3 class 3K3) • Pollution degree: 3 (in accordance with IEC 60664-1)

Accessories

PowerModuleless TR2 (12 to 440V AC) • DC power supply SNT2 24V DC

Dimensions

Measuring ranges ( $U_N$ )

Controls

Indicators (LEDs)

Functions

Switching threshold max.

Tripping delay

Start-up suppression time

Fault latch

Supply

Output

Width

Certificates

Mechanical design

Terminal capacity

Ambient conditions

Accessories

**TUW:**  
AC/DC voltage monitoring in 1-phase mains with adjustable thresholds, timing for start-up suppression and tripping delay separately adjustable and the following functions (selectable by means of DIP switch)

DIP-Switch 1: AC/DC preselection  
DIP-Switch 2: Monitoring inside (W) or outside (R) the window between  $U_{min}$  and  $U_{max}$   
DIP-Switch 3: ON Relay picks up during the start-up suppression time ( $t_2$ )  
OFF Relay remains in off position during the start-up suppression time ( $t_2$ )

**TUH:**  
AC/DC overvoltage monitoring in 1-phase mains with adjustable threshold, timing for start-up suppression and tripping delay separately adjustable and adjustable hysteresis and the following functions (selectable by means of DIP-switch)

DIP-Switch 1: AC/DC preselection  
DIP-Switch 2: REL relay in on-position if error occurs REL relays in off-position if error occurs  
DIP-Switch 3: ON Relay picks up during the start-up suppression time ( $t_2$ )  
OFF Relay remains in off position during the start-up suppression time ( $t_2$ )

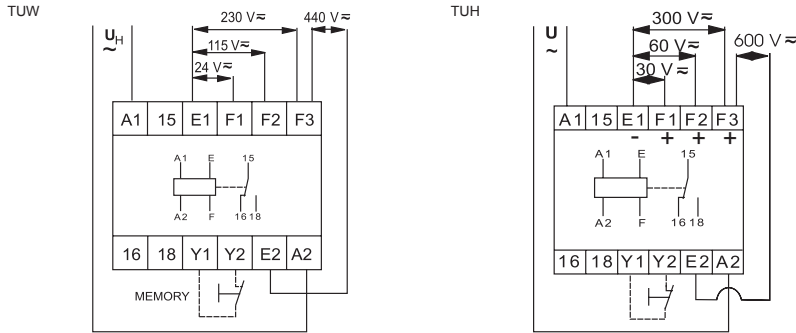

Width 45mm

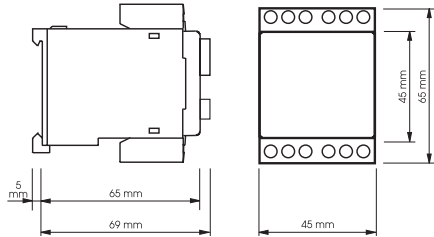

Functions

Sensing & Monitoring Relays Series TREND

Current monitoring in 1-phase mains



- Windowfunction (TIW4X)
- 2 trigger level (TIF)
- Hysteresis OVER/UNDER (TIH4X)
- Position of output relay selectable (TIW4X; TIH4X)
- DIP-Switch for adjusting to AC/DC monitoring and relay position (TIW4X; TIH4X)
- Fault latch (TIW4X; TIH4X)
- Permissible continuous load on measuring input 15A(TIF)
- Supply voltage selectable via PowerModules or DC power supply (TIW4X; TIH4X)
- 1 CO contact; 2 CO contacts; Width 45mm; Industrial design

Connections

types

TIW4X

TIH4X

TIF30-300mAAC4X

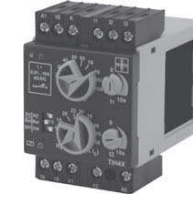

Art.No. (PQ1)  
Art.No. (PQ10)  
EAN13-Code  
Measured variable

Measuring ranges

Controls

Indicators (LEDs)

Functions

Switching threshold max.

Tripping delay

Start-up suppression time

Fault latch

Supply

Output

Width

Certificates

Mechanical design

Terminal capacity

Ambient conditions

Accessories

2430890

2432610

2432894

Current AC/DC  
AC Sinus (48 to 63Hz)

Current AC/DC  
AC Sinus (48 to 63Hz)

Current AC  
AC Sinus (48 to 63Hz)

100mA AC/DC; terminals K-I3(+)  
1A AC/DC; terminals K-I2(+)  
10A AC/DC; terminals K-I1(+)

100mA AC/DC; terminals K-I3(+)  
1A AC/DC; terminals K-I2(+)  
10A AC/DC; terminals K-I1(+)

15A AC; terminals K-I

max • min • Delay ( $t_1$ ) • Start ( $t_2$ ) • AC/DC • REL/REL • Start On/Off

$I_s$  • Hyst • Delay ( $t_1$ ) • Start ( $t_2$ ) • AC/DC • REL/REL • Start On/Off

-

max • R • min

U • R

U • R

WIN

1 trigger level with hysteresis (OVER/UNDER)

UNDER

10% to 100% from  $I_N$

trigger level  $I_s$ ; 10% to 100% from  $I_N$

fixed, 30mA  
fixed, 300mA

5% to 50% from  $I_N$

Hysteresis: 5% to 50% from  $I_s$

Hysteresis: fixed, approx. 5%

$t_1 = 0,1s$  to 10s

$t_1 = 0,1s$  to 10s

-

$t_2 = 0,1s$  to 10s

$t_2 = 0,1s$  to 10s

-

selectable

selectable

-

PowerModule TR2 or SNT2  
terminals A1-A2

PowerModule TR2 or SNT2  
terminals A1-A2

230V AC  
terminals A1-A2

1 CO contact  
250V, 5A AC

1 CO contact  
250V, 5A AC

2 CO contacts  
250V, 5A AC

45mm

45mm

45mm

CE

CE

CE

Self-extinguishing plastic housing, IP rating IP40 • Mounted on DIN-Rail TS 35 in accordance with EN 60715 • Mounting position any • Shockproof terminal connection according to VBG 4 (PZ1 required) • IP rating IP20 • Tightening torque max. 1Nm

1 x 0,5 to 2,5mm<sup>2</sup> with/without multicore cable end • 1 x 4mm<sup>2</sup> without multicore cable end • 2 x 0,5 to 1,5mm<sup>2</sup> with/without multicore cable end • 2 x 2,5mm<sup>2</sup> flexible without multicore cable end

Ambient temperature: -25 to +55°C (in accordance with IEC 60668-1) • Storage temperature: -25 to +70°C • Transport temperature: -25 to +70°C • relative humidity: 15% to 85% (in accordance with IEC 60721-3-3 class 3K3) • Pollution degree: 3 (in accordance with IEC 60664-1)

PowerModulees TR2 (12 to 440V AC) • DC power supply SNT2 24V DC • Current Transformers DWS and WSW

**TIW:** AC/DC current monitoring in 1-phase mains with adjustable thresholds, timing for start-up suppression and tripping delay separately adjustable and the following functions (selectable by means of DIP-switch)

- DIP-Switch 1: AC/DC preselection  
 DIP-Switch 2: W Monitoring inside (W) the window between  $I_{min}$  and  $I_{max}$   
 R Monitoring outside (R) the window between  $I_{min}$  and  $I_{max}$   
 DIP-Switch 3: ON Relay pics up during the start-up suppression time ( $t_2$ )  
 OFF Relay remains in off position during the start-up suppression time ( $t_2$ )

**TIH:** AC/DC overcurrent monitoring in 1-phase mains with adjustable threshold, timing for start-up suppression and tripping delay separately adjustable and adjustable hysteresis and the following functions (selectable by means of DIP-switch)

- DIP-Switch 1: AC/DC preselection  
 DIP-Switch 2: REL relay in on-position if error occurs, REL $\bar$  relays in off-position if error occurs  
 DIP-Switch 3: ON Relay pics up during the start-up suppression time ( $t_2$ )  
 OFF Relay remains in off position during the start-up suppression time ( $t_2$ )

**TIF:** Consumer failure detection for AC-current in 1-phase mains with 2 fixed thresholds (selectable via bridge X1-X2)

TIW4X; TIH4X

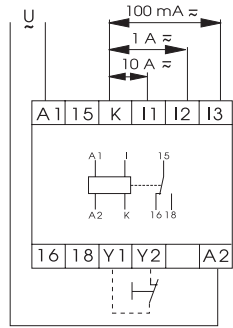

TIF30-300mAAC4X

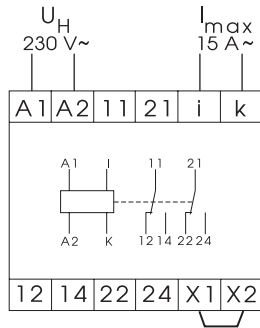

Width 45mm

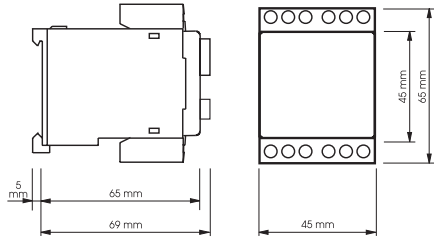

Functions



## Sensing & Monitoring Relays Series TREND

Temperature monitoring



- Temperature monitoring of motor winding
- Maximum of 6 PTC probes per measuring circuit
- 2 measuring circuits (TDT4X)
- Fault latch for measuring circuit 2 (TDT4X)
- Short circuit monitoring of PTC circuits
- Supply voltage selectable via PowerModules or DC power supply (TDT4X)
- 1 NO contact; 1 CO contact per measuring circuit (TDT4X)
- Width 22,5mm or 45mm
- Industrial design

Connections

types

TDT4X

TT2X 24V AC

TT2X 230V AC



Art.No. (PQ1)

2480090

2480052

2480054

Art.No. (PQ10)

-

-

-

EAN13-Code

900866200328

900866200325

900866200327

Measured variable

2 x PTC (motortemperature)  
max. 2 x 6 PTC probes

PTC (motortemperature)  
max. 6 PTC probes

PTC (motortemperature)  
max. 6 PTC probes

Measured range

total resistance cold <1.5k $\Omega$   
terminals 1T1-T2 (circuit 1)  
terminals 2T1-T2 (circuit 2)

total resistance cold <1.5k $\Omega$   
terminals T1-T2

total resistance cold <1.5k $\Omega$   
terminals T1-T2

Measuring voltage

max. 12V DC

max. 12V DC

max. 12V DC

Controls

Test/Reset button

-

-

Indicators (LEDs)

U • Failure 1T1-T2 •  
Failure 2T1-T2

U • Failure

U • Failure

Functions

Overtemperature

Overtemperature

Overtemperature

Response value

3,3k $\Omega$

3,3k $\Omega$

3,3k $\Omega$

Release value

1,8k $\Omega$

1,8k $\Omega$

1,8k $\Omega$

Short circuit monitoring

<15 $\Omega$

<15 $\Omega$

<15 $\Omega$

Fault latch

yes (circuit 2)

-

-

Reset

internal or external  
terminals 2R1-T2/2R2

-

-

Supply

PowerModule TR2 or SNT2  
terminals A1-A2

24V AC  
terminals A1-A2

230V AC  
terminals A1-A2

Output

1 CO contact each circuit  
250V, 5A AC

1 NO contact  
250V, 5A AC

1 NO contact  
250V, 5A AC

Width

45mm

22,5mm

22,5mm

Certificates

CE

CE

CE

Mechanical design

Self-extinguishing plastic housing, IP rating IP40 • Mounted on DIN-Rail TS 35 in accordance with EN 60715 • Mounting position any • Shockproof terminal connection according to VBG 4 (PZ1 required) • IP rating IP20 • Tightening torque max. 1Nm

Terminal capacity

1 x 0,5 to 2,5mm<sup>2</sup> with/without multicore cable end • 1 x 4mm<sup>2</sup> without multicore cable end • 2 x 0,5 to 1,5mm<sup>2</sup> with/without multicore cable end • 2 x 2,5mm<sup>2</sup> flexible without multicore cable end

Ambient conditions

Ambient temperature: -25 to +55°C (in accordance with IEC 60068-1) • Storage temperature: -25 to +70°C • Transport temperature: -25 to +70°C • relative humidity: 15% to 85% (in accordance with IEC 60721-3-3 class 3K3) • Pollution degree: 3 (in accordance with IEC 60664-1)

Accessories

PowerModules TR2 (12 to 440V AC) • DC power supply SNT2 24V DC



Temperature monitoring of motor winding (max. 6 PTC) with fault latch (only measuring circuit 2) for probes in accordance with DIN 44081  
Short circuit monitoring of PTC circuits

Functions



## Sensing & Monitoring Relays Series TREND

Level monitoring



- Level monitoring of conductive substances
- Pump up or minimum monitoring
- Pump down or maximum monitoring
- 1 CO contact
- Width 45mm
- Industrial design

TDT4X

TT2X

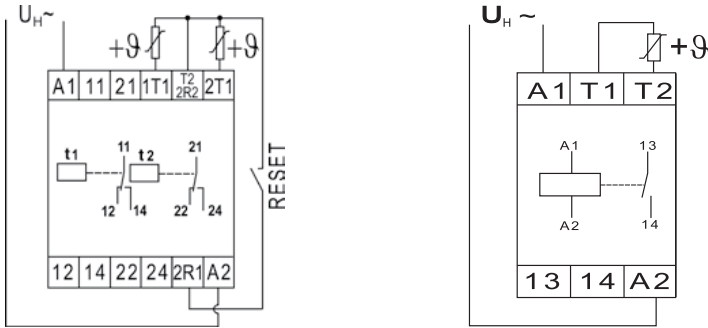

Width 22.5mm

Width 45mm

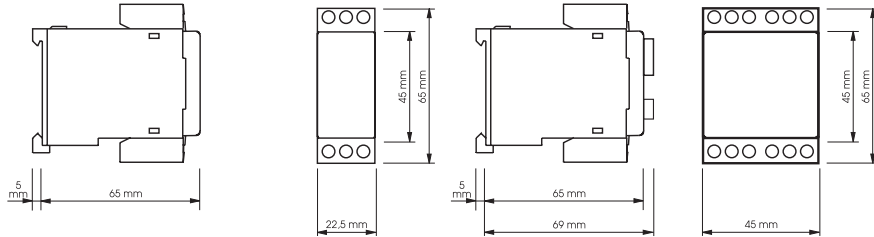

Connections

types

TLH4X 24V AC

TLH4X 230V AC

TLC4X 230V AC



Art.No. (PQ1)  
Art.No. (PQ10)  
EAN13-Code  
Measured variable

Measuring ranges

Probe voltage

Probe current

Wiring distance

Control

Indicators (LEDs)

Functions

Trigger level

Tripping delay

Turn-off delay

Supply

Output

Width

Certificates

Mechanical design

Terminal capacity

Ambient conditions

Accessories

2472012

-

900866200317

conductive probe min.  
conductive probe max.  
terminals E1-E2-E3

0,25 to 5k $\Omega$  / 5 to 100k $\Omega$

max. 16VAC

max. 7mA / max. 200 $\mu$ A

max. 1000m / max. 100m

Sensitivity • Delay on ( $t_1$ ) • Delay off ( $t_2$ ) •  
Function • Measuring ranges

U • R

Pump up  
Pump down

0,25 to 5k $\Omega$  / 5 to 100k $\Omega$   
(Sensitivity)

0,5s to 10s ( $t_1$ )

0,5s to 10s ( $t_2$ )

24V AC  
terminals A1-A2

1 CO contact  
250V, 5A AC

45mm

CE

CE

CE

1 x 0,5 to 2,5mm<sup>2</sup> with/without multicore cable end • 1 x 4mm<sup>2</sup> without multicore cable end • 2 x 0,5 to 1,5mm<sup>2</sup> with/without multicore cable end • 2 x 2,5mm<sup>2</sup> flexible without multicore cable end

Ambient temperature: -25 to +55°C (in accordance with IEC 60068-1) • Storage temperature: -25 to +70°C • Transport temperature: -25 to +70°C • relative humidity: 15% to 85% (in accordance with IEC 60721-3-3 class 3K3) • Pollution degree: 3 (in accordance with IEC 60664-1)

conductive probes (types SK1, SK2, SK3)

2472014

-

900866200318

conductive probe min.  
conductive probe max.  
terminals E1-E2-E3

0,25 to 5k $\Omega$  / 5 to 100k $\Omega$

max. 16VAC

max. 7mA / max. 200 $\mu$ A

max. 1000m / max. 100m

Sensitivity • Delay on ( $t_1$ ) • Delay off ( $t_2$ ) •  
Function • Measuring ranges

U • R

Pump up  
Pump down

0,25 to 5k $\Omega$  / 5 to 100k $\Omega$   
(Sensitivity)

0,5s to 10s ( $t_1$ )

0,5s to 10s ( $t_2$ )

230V AC  
terminals A1-A2

1 CO contact  
250V, 5A AC

45mm

CE

CE

CE

1 x 0,5 to 2,5mm<sup>2</sup> with/without multicore cable end • 1 x 4mm<sup>2</sup> without multicore cable end • 2 x 0,5 to 1,5mm<sup>2</sup> with/without multicore cable end • 2 x 2,5mm<sup>2</sup> flexible without multicore cable end

Ambient temperature: -25 to +55°C (in accordance with IEC 60068-1) • Storage temperature: -25 to +70°C • Transport temperature: -25 to +70°C • relative humidity: 15% to 85% (in accordance with IEC 60721-3-3 class 3K3) • Pollution degree: 3 (in accordance with IEC 60664-1)

conductive probes (types SK1, SK2, SK3)

2472114

-

900866200323

conductive probe min.  
conductive probe max.  
terminals E1-E2-E3

5 to 100k $\Omega$

max. 16VAC

max. 200 $\mu$ A

max. 100m

Sensitivity • Function

U • R

Pump up  
Pump down

5 to 100k $\Omega$   
(Sensitivity)

2s fixed

2s fixed

230V AC  
terminals A1-A2

1 CO contact  
250V, 5A AC

45mm

CE

CE

CE

1 x 0,5 to 2,5mm<sup>2</sup> with/without multicore cable end • 1 x 4mm<sup>2</sup> without multicore cable end • 2 x 0,5 to 1,5mm<sup>2</sup> with/without multicore cable end • 2 x 2,5mm<sup>2</sup> flexible without multicore cable end

Ambient temperature: -25 to +55°C (in accordance with IEC 60068-1) • Storage temperature: -25 to +70°C • Transport temperature: -25 to +70°C • relative humidity: 15% to 85% (in accordance with IEC 60721-3-3 class 3K3) • Pollution degree: 3 (in accordance with IEC 60664-1)

conductive probes (types SK1, SK2, SK3)

Self-extinguishing plastic housing, IP rating IP40 • Mounted on DIN-Rail TS 35 in accordance with EN 60715 • Mounting position any • Shockproof terminal connection according to VBG 4 (PZ1 required) • IP rating IP20 • Tightening torque max. 1Nm

1 x 0,5 to 2,5mm<sup>2</sup> with/without multicore cable end • 1 x 4mm<sup>2</sup> without multicore cable end • 2 x 0,5 to 1,5mm<sup>2</sup> with/without multicore cable end • 2 x 2,5mm<sup>2</sup> flexible without multicore cable end

Ambient temperature: -25 to +55°C (in accordance with IEC 60068-1) • Storage temperature: -25 to +70°C • Transport temperature: -25 to +70°C • relative humidity: 15% to 85% (in accordance with IEC 60721-3-3 class 3K3) • Pollution degree: 3 (in accordance with IEC 60664-1)

conductive probes (types SK1, SK2, SK3)

**TLH:**  
Level monitoring of conductive substances, timing for tripping delay and turn-off delay separately adjustable and the following functions:

Pump down Pump down or maximum monitoring  
Pump up Pump up or minimum monitoring

**TLC:**  
Level monitoring of conductive substances with adjustable threshold, fixed tripping delay and turn-off delay and the following functions:

Pump down Pump down or maximum monitoring  
Pump up Pump up or minimum monitoring

Connection of 3-probes (pump up/down)

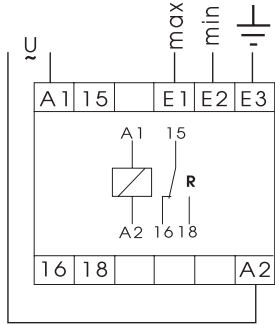

Connection of 2-probes (Minimum-/Maximum monitoring)

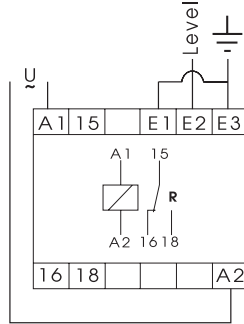

Width 45mm

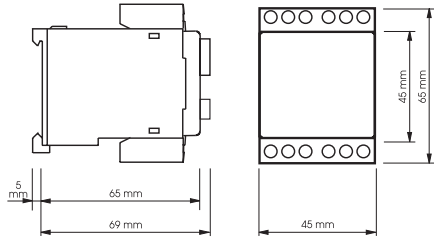

Functions



Sensing & Monitoring Relays Series KAPPA



Voltage and current monitoring of mains

- AC voltage monitoring in 1- and 3-phase mains (K3YM)
- AC/DC voltage monitoring in 1-phase mains (K3UM)
- AC current monitoring in 1-phase mains (K3IM)
- Monitoring of phase sequence, phase failure and asymmetry (K3PF)
- Monitoring of phase failure; monitoring of phase sequence selectable (K3YM)
- Multifunction (K3YM; K3IM; K3UM)
- Supply voltage = measuring voltage (K3PF; K3YM; K3UM)
- Supply voltage = 230V (K3IM)
- 2 CO contacts; Width 38mm; Plug-in mounting

Connections

types K3YM400VSY20 K3PF400VSY02 K3UM230VAC02 K3UM24VDC02 K3IM5AACL20 230V



	K3YM400VSY20	K3PF400VSY02	K3UM230VAC02	K3UM24VDC02	K3IM5AACL20 230V
Art.No. (PQ1)	1380402	1380301	1380107	1380106	1380202
Art.No. (PQ10)	-	-	-	-	-
EAN13-Code	9008662005419	9008662005426	9008662005396	9008662005402	9008662005433
Measured variable	3(N)~ AC Sinus (48 to 63Hz)	3(N)~ AC Sinus (48 to 63Hz)	Voltage AC AC Sinus (48 to 63Hz)	Voltage DC	Current AC AC Sinus (48 to 63Hz)
Measured range	$U_N = 400/230V$ pins (S10)-S5-S6-S7	$U_N = 400/230V$ pins (S10)-S5-S6-S7	230V AC pins S5-S7	24V DC pins S5-S7	5A AC pins S5-S7
Control	ASYM • Max • Min • Function / Delay	ASYM	Max • Min • Function	Max • Min • Function	Start • Max • Min • Function • Delay
Indicators (LEDs)	ASYM • SEQ • Max • Min • R	U • R	U • Max • Min • R	U • Max • Min • R	U! • Max • Min • R
Functions	UNDER • UNDER+SEQ • WIN • WIN+SEQ	Monitoring of phase sequence, phase failure and asymmetry	UNDER • WIN	UNDER • WIN	OVER • OVER+Latch • UNDER • UNDER+Latch • WIN • WIN+Latch
Asymmetry	5% to 30%; Off	5% to 30%; Off	-	-	-
Switching threshold max.	80% to 130% of $U_N$	-	80% to 120% of $U_N$	80% to 130% of $U_N$	10% to 100% of $I_N$
Switching threshold min.	70% to 120% of $U_N$	-	70% to 110% of $U_N$	75% to 125% of $U_N$	5% to 95% of $I_N$
Hysteresis	adjustable	-	adjustable	adjustable	adjustable
Tripping delay	0,1s to 10s	fixed circa 100ms	-	-	0,1s to 10s
Start-up suppression time	-	-	-	-	0s to 10s
Fault latch	-	-	-	-	selectable
Supply	= measuring voltage 3(N)-400/230V -30% to +30% pins (S10)-S5-S6-S7	= measuring voltage 3(N)-400/230V -30% to +30% pins (S10)-S5-S6-S7	= measuring voltage 230V AC -30% to +20% pins S5-S7	= measuring voltage 24V DC -25% to +30% pins S5-S7	230V AC -15% to +10% pins S2-S10
Output	2 CO contacts 250V, 5A AC	2 CO contacts 250V, 5A AC	2 CO contacts 250V, 5A AC	2 CO contacts 250V, 5A AC	2 CO contacts 250V, 5A AC
Width	38mm	38mm	38mm	38mm	38mm
Certificates	CE • GOST	CE • GOST	CE • GOST	CE • GOST	CE • GOST
Mechanical design	Self-extinguishing plastic housing, IP rating IP40 • Mounted on 11-pole screw terminal socket in accordance with IEC 60067-1-18a • Mounting position any				
Ambient conditions	Ambient temperature: -25 to +55°C (in accordance with IEC 60068-1) • Storage temperature: -25 to +70°C • Transport temperature: -25 to +70°C • relative humidity: 15% to 85% (in accordance with IEC 60721-3-3 class 3K3) • Pollution degree: 2, if built in 3 (in accordance with IEC 60664-1)				
Accessories	Relay socket R11X, ES12				

Dimensions

**K3YM:** Voltage monitoring in 1-phase- and 3-phase mains with adjustable thresholds, adjustable tripping delay, monitoring of phase failure and monitoring of phase sequence selectable.

**K3IM:** AC current monitoring in 1-phase mains with adjustable thresholds, adjustable hysteresis and tripping delay.

**K3UM:** AC/DC voltage monitoring in 1-phase mains with adjustable thresholds and adjustable hysteresis.

**K3PF:** Monitoring of phase sequence, phase failure and asymmetry with adjustable asymmetry, connection of neutral wire optional.

OVER	Overcurrent monitoring
UNDER	Undercurrent or undervoltage monitoring
WIN	Monitoring the window between Min and Max
OVER+Latch	Overcurrent monitoring with fault latch
UNDER+Latch	Undercurrent monitoring with fault latch
WIN+Latch	Monitoring the window between Min and Max with fault latch
UNDER+SEQ	Undervoltage monitoring and monitoring of phase sequence
WIN+SEQ	Monitoring the window between Min and Max and monitoring of phase sequence

K3UM24VDC02

K3UM230VAC02

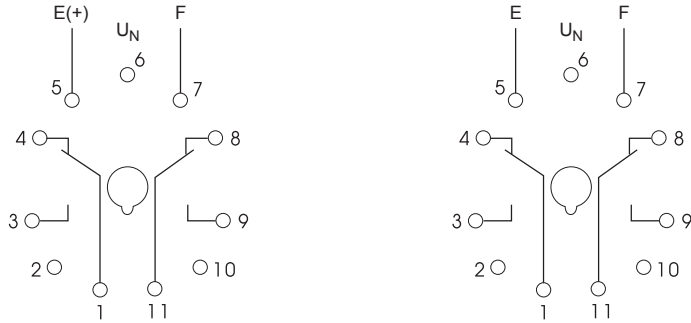

K3IM5AACL20 230V

K3PF400VSY02

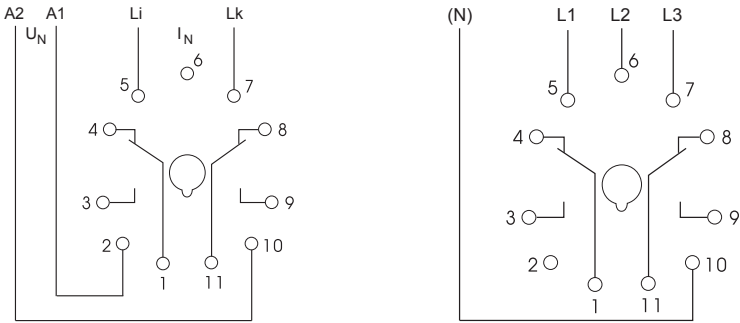

K3YM400VSY20

Width 38mm

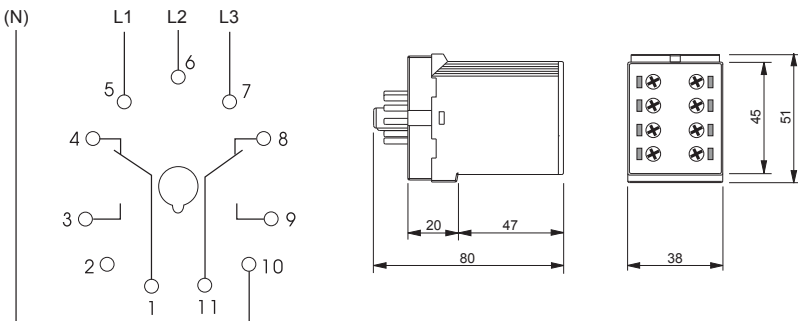

Functions

Connections

Connections

Connections

Dimensions



Sensing & Monitoring Relays Series ENYA

Voltage monitoring in 3- and 1-phase mains



- UNDERvoltage monitoring
- Integrated testswitch (E3YF400VT02 0.85)
- Start-up delay time in accordance with VDE 0108-100 and VDE 0100-718 (E3YF400VE20 0.85)
- Supply voltage = measuring voltage
- 2 CO contacts
- Width 35mm
- Installation design

types

E3YF400V02 0.85

E3YF400VE20 0.85

E3YF400VT02 0.85

E3YF400VT02 HTV 0.85



Art.No. (PQ1)  
Art.No. (PQ10)  
EAN13-Code  
Measured variable

Measured range

Control

Indicators (LEDs)

Functions

Asymmetry

Switching threshold max.

Switching threshold min.

Hysteresis

Tripping delay

Start-up delay time

Fault latch

Supply

Output

Width

Certificates

Mechanical design

Terminal capacity

Ambient conditions

Accessories

	E3YF400V02 0.85	E3YF400VE20 0.85	E3YF400VT02 0.85	E3YF400VT02 HTV 0.85
Art.No. (PQ1)	1341401	1341404	1341402	1341407
Art.No. (PQ10)	-	-	-	-
EAN13-Code	9008662005303	9008662005785	9008662005297	9008662006416
Measured variable	3N~ AC Sinus (48 to 63Hz)	3N~ AC Sinus (48 to 63Hz)	3N~ AC Sinus (48 to 63Hz)	3N~ AC Sinus (48 to 63Hz)
Measured range	$U_N = 400/230V$ terminals N-L1-L2-L3	$U_N = 400/230V$ terminals N-L1-L2-L3	$U_N = 400/230V$ terminals N-L1-L2-L3	$U_N = 400/230V$ terminals N-L1-L2-L3
Control	-	-	Testfunction	Testfunction
Indicators (LEDs)	U • R	L1 • L2 • L3 • R	L1 • L2 • L3 • R	L1 • L2 • L3 • R
Functions	UNDER	UNDER	UNDER TEST (R=OFF)	UNDER TEST (R=OFF)
Asymmetry	-	-	-	-
Switching threshold max.	-	-	-	-
Switching threshold min.	fixed 195,5V (L-N) in accordance with VDE 0100-718 VDE 0108-100 $0,85 \times U_N$	fixed 195,5V (L-N) in accordance with VDE 0100-718 VDE 0108-100 $0,85 \times U_N$	fixed 195,5V (L-N) in accordance with VDE 0100-718 VDE 0108-100 $0,85 \times U_N$	fixed 195,5V (L-N) in accordance with VDE 0100-718 VDE 0108-100 $0,85 \times U_N$
Hysteresis	approx. 5%	approx. 5%	approx. 5%	approx. 5%
Tripping delay	fixed, approx. 200ms	fixed, < 500ms	fixed, approx. 200ms	fixed, approx. 200ms
Start-up delay time	-	60 sec	-	-
Fault latch	-	-	-	-
Supply	= measuring voltage 3N~400/230V -30% to +10% terminals N-L1-L2-L3	= measuring voltage 3N~400/230V -30% to +10% terminals N-L1-L2-L3	= measuring voltage 3N~400/230V -30% to +10% terminals N-L1-L2-L3	= measuring voltage 3N~400/230V -30% to +10% terminals N-L1-L2-L3
Output	2 CO contacts 250V, 5A AC	2 CO contacts 250V, 5A AC	2 CO contacts 250V, 5A AC	2 CO contacts 250V, 5A AC
Width	35mm	35mm	35mm	35mm
Certificates	CE • cULus • GOST	CE • cULus • GOST	CE • cULus • GOST	CE • cULus • GOST
Mechanical design	Self-extinguishing plastic housing, IP rating IP40 • Mounted on DIN-Rail TS 35 in accordance with EN 60715 • Mounting position any • Shockproof terminal connection according to VBG 4 (PZ1 required), IP rating IP20 • Tightening torque max. 1Nm			
Terminal capacity	1 x 0,5 to 2,5mm <sup>2</sup> with/without multicore cable end • 1 x 4mm <sup>2</sup> without multicore cable end • 2 x 0,5 to 1,5mm <sup>2</sup> with/without multicore cable end • 2 x 2,5mm <sup>2</sup> flexible without multicore cable end			
Ambient conditions	Ambient temperature: -25 to +55°C (in accordance with IEC 60068-1) • Storage temperature: -25 to +70°C • Transport temperature: -25 to +70°C • relative humidity: 15% to 85% (in accordance with IEC 60721-3-3 class 3K3) • Pollution degree: 2 (in accordance with IEC 60664-1)			
Accessories	-			

**E3YF400V02 0.85**  
 Undervoltage monitoring in single-phase and 3-phase mains  
 UNDER Undervoltage monitoring

**E3YF400VT02 0.85**  
 Undervoltage monitoring in single-phase and 3-phase mains  
 UNDER Undervoltage monitoring  
 T Integrated test switch

**E3YF400VE20 0.85**  
 Undervoltage monitoring in single-phase and 3-phase mains  
 UNDER Undervoltage monitoring  
 On delay as per VDE 0100-718

E3YF

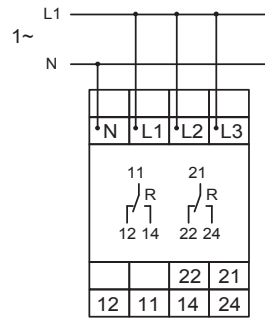
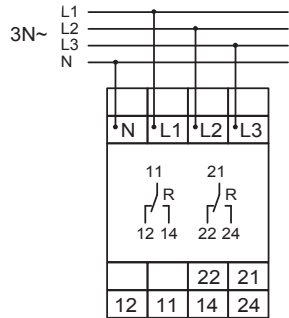

E3YF

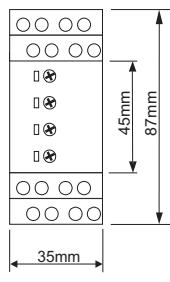
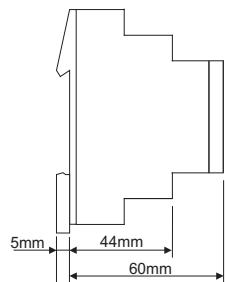

Width 35mm

E3YF

Functions



## Sensing & Monitoring Relays Series ENYA

Voltage monitoring in 3- and 1-phase mains

**WatchDog**



- Undervoltage monitoring
- Integrated testswitch (E1YF400VT01 0.85)
- Supply voltage = measuring voltage
- 1 CO contact
- Width 17,5mm
- Installation design

Connections

Type

E1YF400V01 0.85

E1YF400VT01 0.85

E1YF400V01 0.70



Art.No. (PQ1)

1340402

1340406

1340410

Art.No. (PQ10)

1340402A

-

-

EAN13-Code

900866200057

900866200487

9008662006140

Measured variable

3N~  
AC Sinus (48 to 63Hz)

3N~  
AC Sinus (48 to 63Hz)

3N~  
AC Sinus (48 to 63Hz)

Measured range

$U_N = 400/230V$   
terminals N-L1-L2-L3

$U_N = 400/230V$   
terminals N-L1-L2-L3

$U_N = 400/230V$   
terminals N-L1-L2-L3

Control

-

Testfunction

-

Indicators (LEDs)

R

L1 • L2 • L3 • R

R

Functions

UNDER

UNDER  
TEST (R=OFF)

UNDER

Asymmetry

-

-

-

Switching threshold min.

-

-

-

Switching threshold min.

fixed 195,5V (L-N)  
in accordance with  
VDE 0100-718  
VDE 0108-100  
 $0,85 \times U_N$

fixed 195,5V (L-N)  
in accordance with  
VDE 0100-718  
VDE 0108-100  
 $0,85 \times U_N$

fixed 161V (L-N)

Hysteresis

ca. 5%

ca. 5%

ca. 5%

Tripping delay

fixed, ca. 200ms

fixed, ca. 200ms

fixed, ca. 200ms

Start-up delay time

-

-

-

Fault latch

-

-

-

Supply

= measuring voltage  
3N~400/230V -30% to +10%  
terminals N-L1-L2-L3

= measuring voltage  
3N~400/230V -30% to +10%  
terminals N-L1-L2-L3

= measuring voltage  
3N~400/230V -30% to +10%  
terminals N-L1-L2-L3

Output

1 CO contact  
250V, 5A AC

1CO contact  
250V, 5A AC

1 CO contact  
250V, 5A AC

Width

17,5mm

17,5mm

17,5mm

Certificates

CE • cULus • GOST

CE • cULus • GOST

CE • GOST

Mechanical design

Self-extinguishing plastic housing, IP rating IP40 • Mounted on DIN-Rail TS 35 in accordance with EN 60715 • Mounting position any • Shockproof terminal connection according to VBG 4 (PZ1 required), IP rating IP20 • Tightening torque max. 1Nm

Terminal capacity

1 x 0,5 to 2,5mm<sup>2</sup> with/without multicore cable end • 1 x 4mm<sup>2</sup> without multicore cable end • 2 x 0,5 to 1,5mm<sup>2</sup> with/without multicore cable end • 2 x 2,5mm<sup>2</sup> flexible without multicore cable end

Ambient conditions

Ambient temperature: -25 to +55°C (in accordance with IEC 60668-1) • Storage temperature: -25 to +70°C • Transport temperature: -25 to +70°C • relative humidity: 15% to 85% (in accordance with IEC 60721-3-3 class 3K3) • Pollution degree: 2 (in accordance with IEC 60664-1)

Accessories

-

Connections

Dimensions

**E1YF400V01 0.85**  
Voltage monitoring in 1-phase and 3-phase mains  
UNDER Undervoltage monitoring

**E1YF400VT01 0.85**  
Voltage monitoring in 1-phase and 3-phase mains  
UNDER Undervoltage monitoring  
T Integrated testswitch

E1YF

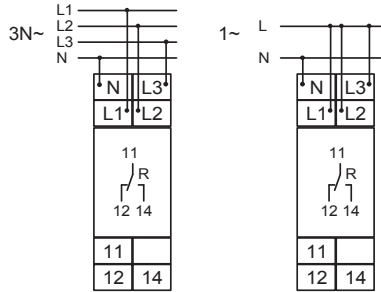

Width 17,5mm

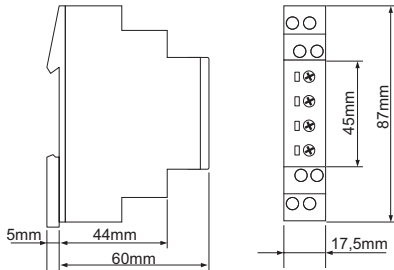

Functions



- Multifunction
- Monitoring of phase failure
- Monitoring of phase sequence selectable
- Connection of neutral wire optional
- Supply voltage = measuring voltage
- 1 CO contact; 2 CO contacts
- Width 17,5mm; 35mm
- Installation design

Connections

types

E3YM230VS20

E1YM400VS10

E1YM480Y/277VS10



Art.No. (PQ1)  
Art.No. (PQ10)  
EAN13-Code  
Measured variable

Measured range

Control

Indicators (LEDs)

Functions

Asymmetry

Switching threshold min.

Switching threshold min.

Hysteresis

Tripping delay

Start-up delay time

Fault latch

Supply

Output

Width

Certificates

Mechanical design

Terminal capacity

Ambient conditions

Accessories

Dimensions

## Sensing & Monitoring Relays Serie ENYA

Voltage monitoring in 3- and 1-phase mains

WatchDog



	E3YM230VS20	E1YM400VS10	E1YM480Y/277VS10
Art.No. (PQ1)	1340406	1340405	1340409
Art.No. (PQ10)	-	-	-
EAN13-Code	9008662006393	900866200484	9008662006768
Measured variable	3(N)~ AC Sinus (48 bis 63Hz)	3(N)~ AC Sinus (48 bis 63Hz)	3(N)~ AC Sinus (48 bis 63Hz)
Measured range	$U_N = 230/132V$ terminals (N)-L1-L2-L3	$U_N = 400/230V$ terminals (N)-L1-L2-L3	$U_N = 480/277V$ terminals L1-L2-L3
Control	Delay • Max • Min • Function	Delay • max • min • Function	Delay • max • min • Function
Indicators (LEDs)	SEQ • Max • Min • R	SEQ • max • min • R	SEQ • max • min • R
Functions	UNDER UNDER+SEQ WIN WIN+SEQ	UNDER UNDER+SEQ WIN WIN+SEQ	UNDER UNDER+SEQ WIN WIN+SEQ
Asymmetry	-	-	-
Switching threshold min.	80% to 130% of $U_N$	80% to 130% of $U_N$	75% to 110% of $U_N$
Switching threshold min.	70% to 120% of $U_N$	70% to 120% of $U_N$	65% to 100% of $U_N$
Hysteresis	-	-	-
Tripping delay	0 to 10s	0,1 to 10s	0,1 to 10s
Start-up delay time	-	-	-
Fault latch	-	-	-
Supply	= measuring voltage 3(N)-230/132V -30% to +30% terminals (N)-L1-L2-L3	= measuring voltage 3(N)-400/230V -30% to +30% terminals (N)-L1-L2-L3	= measuring voltage 3-480/277V -35% to +10% terminals L1-L2-L3
Output	2 CO contacts 250V, 5A AC	1 CO contact 250V, 5A AC	1 CO contact 250V, 5A AC
Width	35mm	17,5mm	17,5mm
Certificates	CE • cULus • GOST	CE • cULus • GOST	CE • GOST
Mechanical design	Self-extinguishing plastic housing, IP rating IP40 • Mounted on DIN-Rail TS 35 in accordance with EN 60715 • Mounting position any • Shockproof terminal connection according to VBG 4 (PZ1 required), IP rating IP20 • Tightening torque max. 1Nm		
Terminal capacity	1 x 0,5 to 2,5mm <sup>2</sup> with/without multicore cable end • 1 x 4mm <sup>2</sup> without multicore cable end • 2 x 0,5 to 1,5mm <sup>2</sup> with/without multicore cable end • 2 x 2,5mm <sup>2</sup> flexible without multicore cable end		
Ambient conditions	Ambient temperature: -25 to +55°C (in accordance with IEC 60068-1) • Storage temperature: -25 to +70°C • Transport temperature: -25 to +70°C • relative humidity: 15% to 85% (in accordance with IEC 60721-3-3 class 3K3) • Pollution degree: 2 (in accordance with IEC 60664-1)		
Accessories	-		

**E1YM, E3YM**

Voltage monitoring in single-phase and 3-phase mains with adjustable thresholds, adjustable trip delay, monitoring of phase breakdown and phase sequence and the following functions that can be selected via rotary switches:

UNDER	Undervoltage monitoring
UNDER+SEQ	Undervoltage and phase sequence monitoring
WIN	Window monitoring, monitoring of range between the min and max thresholds
WIN+SEQ	Monitoring the window between Min and Max and monitoring of phase sequence

**E3YM230VS20**

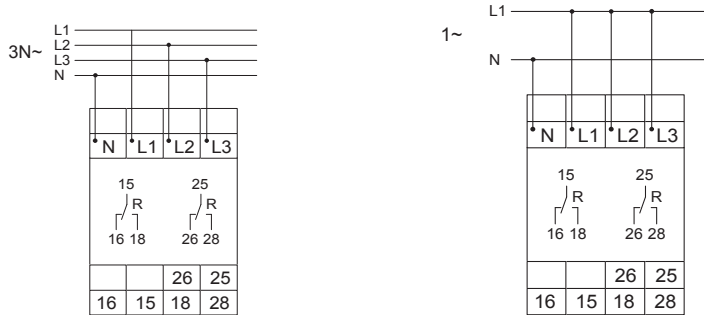

**E1YM400VS10**

**E1YM480Y/277VS10**

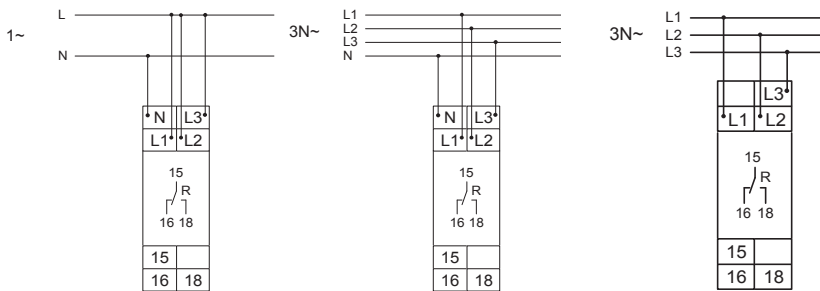

Width 17,5mm

Width 35mm

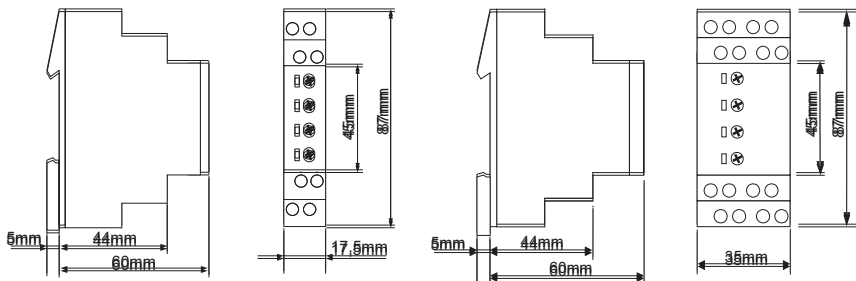

Functions



**Sensing & Monitoring Relays Series ENYA**

Voltage monitoring in 3- and 1-phase mains

**WatchDog**



- Undervoltage monitoring
- Supply voltage = measuring voltage
- 1 CO contact; 2 CO contacts
- Width 17,5mm; 35mm
- Installation design

Connections

types

E3YU400V02

E1YU400V01



Art.No. (PQ1)  
Art.No. (PQ10)  
EAN13-Code

Measured variable

Measured range

Control

Indicators (LEDs)

Functions

Asymmetry

Switching threshold min.

Hysteresis

Tripping delay

Start-up suppression time

Fault latch

Supply

Output

Width

Certificates

Mechanical design

Terminal capacity

Ambient conditions

Accessories

1341403

-

9008662005617

3(N)~  
AC Sinus (48 to 63Hz)  
 $U_n = 400/230V$   
terminals N-L1-L2-L3

$U_s$

L1 • L2 • L3 • R

UNDER

-

160-240V (L-N)

approx. 5%

fixed approx. 200ms

-

-

= measuring voltage  
3(N)~400/230V -30% to +10%  
terminals (N)-L1-L2-L3

2 CO contacts  
250V, 5AAC

35mm

CE • cULus • GOST

Self-extinguishing plastic housing, IP rating IP40 • Mounted on DIN-Rail TS 35 in accordance with EN 60715 • Mounting position any • Shockproof terminal connection according to VBG 4 (PZ1 required), IP rating IP20 • Tightening torque max. 1Nm

1 x 0,5 to 2,5mm<sup>2</sup> with/without multicore cable end • 1 x 4mm<sup>2</sup> without multicore cable end • 2 x 0,5 to 1,5mm<sup>2</sup> with/without multicore cable end • 2 x 2,5mm<sup>2</sup> flexible without multicore cable end

Ambient temperature: -25 to +55°C (in accordance with IEC 60068-1) • Storage temperature: -25 to +70°C • Transport temperature: -25 to +70°C • relative humidity: 15% to 85% (in accordance with IEC 60721-3-3 class 3K3) • Pollution degree: 2 (in accordance with IEC 60664-1)

-

1340403

-

9008662000059

3(N)~  
AC Sinus (48 to 63Hz)  
 $U_n = 400/230V$   
terminals N-L1-L2-L3

$U_s$

L1 • L2 • L3 • R

UNDER

-

160-240V (L-N)

approx. 5%

fixed, approx. 200ms

-

-

= measuring voltage  
3(N)~400/230V -30% to +10%  
terminals (N)-L1-L2-L3

1 CO contact  
250V, 5AAC

17,5mm

CE • cULus • GOST

**E1YU, E3YU**

Undervoltage monitoring in 4-wire systems (each phase against neutral), with adjustable setpoint (E1YU) and with fixed hysteresis.

**E3YU**

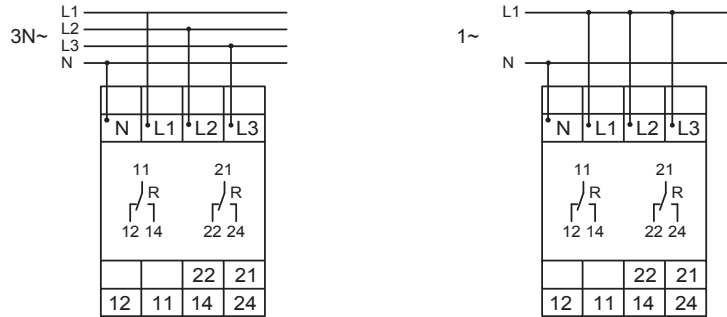

**E1YU**

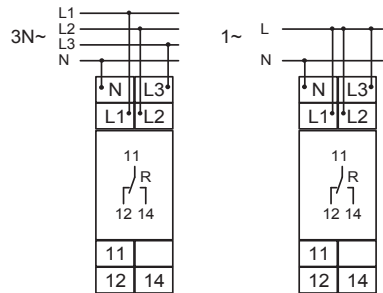

Width 17,5mm

Width 35mm

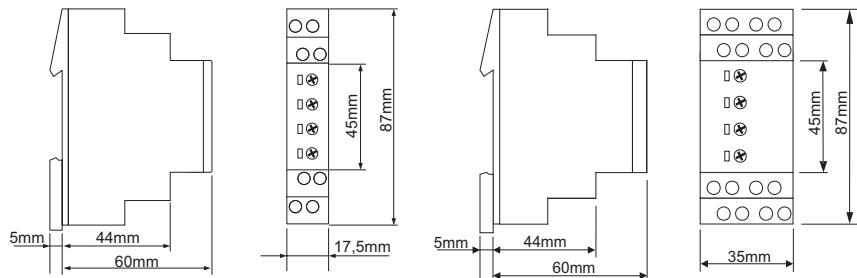

Functions



**Sensing & Monitoring Relays Series ENYA**

Voltage monitoring in 3- and 1-phase mains



- Voltage monitoring in accordance with VDE 0126-1-1
- Quick net error recognition
- Supply voltage = measuring voltage
- 2 CO contacts
- Width 35mm
- Installation design

Connections

types

E3YF400VFAL02



Art.No. (PQ1)  
Art.No. (PQ10)  
EAN13-Code  
Measured variable

Connections

Measured range

Control

Indicators (LEDs)

Functions

Asymmetry

Switching threshold min.

Delay

On-delay

Fault latch

Supply

Output

Width

Certificates

Mechanical design

Terminal capacity

Ambient conditions

Accessories

1341400

-

9008662005198

3(N)~  
AC Sinus (48 to 63Hz)  
 $U_N = 400/230V$   
terminals (N)-L1-L2-L3

Latch • Average

U/t • R

WIN  
WIN+LATCH

fixed +15% from  $U_N$   
fixed -20% from  $U_N$

10-minute-average: +10% to +15% from  $U_N$

$U \leq 80\%$  from  $U_N$  <200ms  
 $U \geq 115\%$  from  $U_N$  <200ms  
phase failure <20ms

fixed 30s

selectable

= measuring voltage  
3(N)-400/230V  
terminals (N)-L1-L2-L3

2 CO contacts  
250V, 5A AC

35mm

CE • cULus • GOST

Self-extinguishing plastic housing, IP rating IP40 • Mounted on DIN-Rail TS 35 in accordance with EN 60715 • Mounting position any • Shockproof terminal connection according to VBG 4 (PZ1 required), IP rating IP20 • Tightening torque max. 1Nm

1 x 0,5 to 2,5mm<sup>2</sup> with/without multicore cable end • 1 x 4mm<sup>2</sup> without multicore cable end • 2 x 0,5 to 1,5mm<sup>2</sup> with/without multicore cable end • 2 x 2,5mm<sup>2</sup> flexible without multicore cable end

Ambient temperature: -25 to +55°C (in accordance with IEC 60068-1) • Storage temperature: -25 to +70°C • Transport temperature: -25 to +70°C • relative humidity: 15% to 85% (in accordance with IEC 60721-3-3 class 3K3) • Pollution degree: 2, if built in 3 (in accordance with IEC 60664-1)

-



**E3YF400VFAL02**

Voltage monitoring in 3-phase mains in accordance with VDE 0126-1-1 with fixed tripping delay, fixed threshold, adjustable 10-minute-average and selectable fault latch by means of rotary switch.

WIN Monitoring the fixed adjusted range  
 WIN+Latch Monitoring the fixed adjusted range with fault latch

**E3YF400VFAL02**

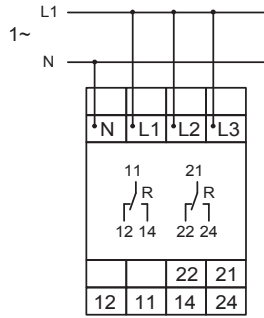
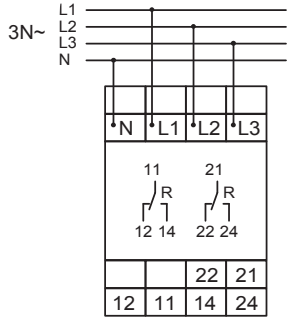

Width 35mm

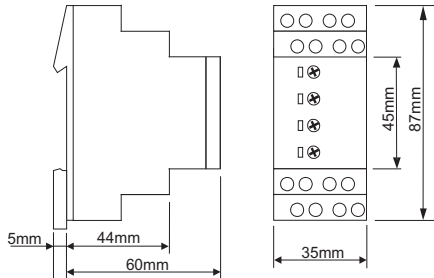

Functions



**Sensing & Monitoring Relays Series ENYA**

Voltage monitoring in 3- and 1-phase mains

**WatchDog**



- Monitoring of phase sequence, phase failure and asymmetry
- Connection of neutral wire optional (E1PF400VSY01, E3PF400VSY02)
- Supply voltage = measuring voltage
- 1 CO contact; 2 CO contacts
- Width 17,5mm or 35mm
- Installation design

Connections

types

E3PF400VSY02

E1PF400VSY01

E1PF480Y/277VSY10



Art.No. (PQ1)

1341300

1340300

1340305

Art.No. (PQ10)

-

-

-

EAN13-Code

900866200513

900866200486

-

Measured variable

3(N)~  
AC Sinus (48 to 63Hz)  
 $U_N = 400/230V$   
terminals (N)-L1-L2-L3

3(N)~  
AC Sinus (48 to 63Hz)  
 $U_N = 400/230V$   
terminals (N)-L1-L2-L3

3~  
AC Sinus (48 to 63Hz)  
terminals L1-L2-L3

Measured range

ASYM  
U • R

ASYM  
U • R

Delay • ASYM  
U • Failure • R

Functions

Monitoring of phase sequence, phase failure and asymmetry

Monitoring of phase sequence, phase failure and asymmetry

Monitoring of phase sequence, phase failure and asymmetry

Asymmetry

5% to 25%, OFF

5% to 25%; OFF

5% to 25%, OFF

Switching threshold max.

-

-

-

Switching threshold min.

-

-

-

Hysteresis

-

-

-

Tripping delay

fixed, approx. 100ms

fixed, approx. 100ms

0,1s to 20s

Start-up suppression time

-

-

-

Fault latch

-

-

-

Supply

= measuring voltage  
3(N)~400/230V -30% to +30%  
terminals (N)-L1-L2-L3

= measuring voltage  
3(N)~400/230V -30% to +30%  
terminals (N)-L1-L2-L3

= measuring voltage  
3~208/120V to 480/277V  
-10% to +10% from  $U_N$   
terminals L1-L2-L3

Output

2 CO contacts  
250V, 5A AC

1 CO contact  
250V, 5A AC

1 CO contact  
250V, 5A AC

Width

35mm

17,5mm

17,5mm

Certificates

CE • cULus • GOST

CE • cULus • GOST

CE • cULus • GOST

Mechanical design

Self-extinguishing plastic housing, IP rating IP40 • Mounted on DIN-Rail TS 35 in accordance with EN 60715 • Mounting position any • Shockproof terminal connection according to VBG 4 (PZ1 required), IP rating IP20 • Tightening torque max. 1Nm

Terminal capacity

1 x 0,5 to 2,5mm<sup>2</sup> with/without multicore cable end • 1 x 4mm<sup>2</sup> without multicore cable end • 2 x 0,5 to 1,5mm<sup>2</sup> with/without multicore cable end • 2 x 2,5mm<sup>2</sup> flexible without multicore cable end

Ambient conditions

Ambient temperature: -25 to +55°C (in accordance with IEC 60068-1) • Storage temperature: -25 to +70°C • Transport temperature: -25 to +70°C • relative humidity: 15% to 85% (in accordance with IEC 60721-3-3 class 3K3) • Pollution degree: 2, if built in 3 (in accordance with IEC 60664-1)

Accessories

-

Dimensions

**E1PF; E3PF**

Monitoring of phase sequence, phase failure and asymmetry with adjustable asymmetry, connection of neutral wire optional.

E1PF400VSY01

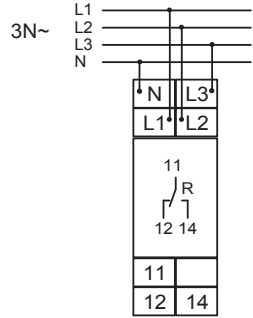

E3PF400VSY02

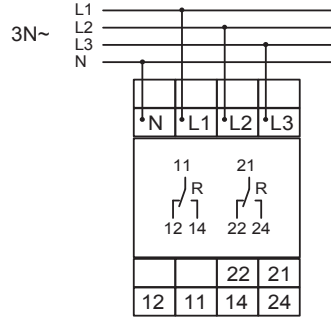

E1PF480Y/277VSY10

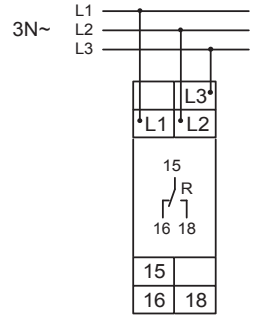

Width 17,5mm

Width 35mm

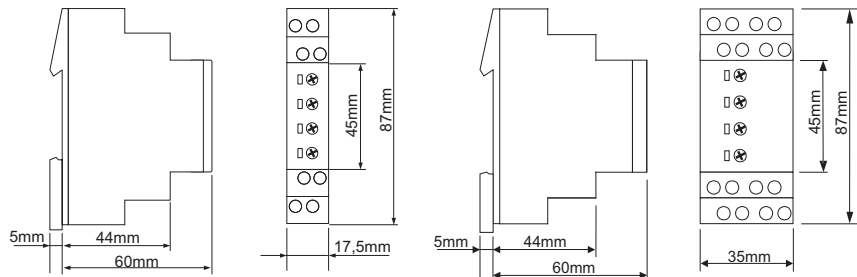

Functions



Sensing & Monitoring Relays Series ENYA

Voltage monitoring in 1-phase mains



- AC/DC voltage monitoring in 1-phase mains
- Multifunction (E1UM)
- Undervoltage monitoring (E1UU)
- Supply voltage = measuring voltage
- 1 CO contact
- Width 17,5mm
- Installation design

Connections

types

E1UM230V01

E1UU230V01



Art.No. (PQ1)  
Art.No. (PQ10)  
EAN13-Code  
Measured variable

Measuring ranges

Controls

Indicators (LEDs)

Functions

Switching threshold max.

Switching threshold min.

Hysteresis

Tripping delay

Start-up suppression time

Fault latch

Supply

Output

Width

Certificates

Mechanical design

Terminal capacity

Ambient conditions

Accessories

	E1UM230V01	E1UU230V01
Art.No. (PQ1)	1340101	1340102
Art.No. (PQ10)	-	-
EAN13-Code	900866200510	900866200505
Measured variable	Voltage AC/DC AC Sinus (48 to 63Hz)	Voltage AC/DC AC Sinus (48 to 63Hz)
Measuring ranges	24V DC; terminals E-F1(+) 24V AC; terminals E-F2 230V AC; terminals E-F3	24V DC; terminals E-F1(+) 24V AC; terminals E-F2 230V AC; terminals E-F3
Controls	Max • Min • Function	Min
Indicators (LEDs)	U • Max • Min • R	U • R
Functions	UNDER WIN	UNDER
Switching threshold max.	80% to 120% from U <sub>N</sub>	-
Switching threshold min.	75% to 115% from U <sub>N</sub>	75% to 115% from U <sub>N</sub>
Hysteresis	adjustable	fixed 5%
Tripping delay	-	-
Start-up suppression time	-	-
Fault latch	-	-
Supply	= measuring voltage 24V DC; terminals E-F1(+) 24V AC; terminals E-F2 230V AC; terminals E-F3 -25% to +20%	= measuring voltage 24V DC; terminals E-F1(+) 24V AC; terminals E-F2 230V AC; terminals E-F3 -25% to +20%
Output	1 CO contact 250V, 5A AC	1 CO contact 250V, 5A AC
Width	17,5mm	17,5mm
Certificates	CE • cULus • GOST	CE • cULus • GOST
Mechanical design	Self-extinguishing plastic housing, IP rating IP40 • Mounted on DIN-Rail TS 35 in accordance with EN 60715 • Mounting position any • Shockproof terminal connection according to VBG 4 (PZ1 required), IP rating IP20 • Tightening torque max. 1Nm	
Terminal capacity	1 x 0,5 to 2,5mm <sup>2</sup> with/without multicore cable end • 1 x 4mm <sup>2</sup> without multicore cable end • 2 x 0,5 to 1,5mm <sup>2</sup> with/without multicore cable end • 2 x 2,5mm <sup>2</sup> flexible without multicore cable end	
Ambient conditions	Ambient temperature: -25 to +55°C (in accordance with IEC 60068-1) • Storage temperature: -25 to +70°C • Transport temperature: -25 to +70°C • relative humidity: 15% to 85% (in accordance with IEC 60721-3-3 class 3K3) • Pollution degree: 2 (in accordance with IEC 60664-1)	
Accessories	-	

Dimensions

### E1UM

AC/DC voltage monitoring in 1-phase mains with adjustable thresholds and hysteresis.

UNDER Undervoltage monitoring  
WIN Monitoring the window between Min and Max

### E1UU

AC/DC UNDERvoltage monitoring in 1-phase mains with adjustable threshold and fixed hysteresis.

UNDER Undervoltage monitoring

E1UM; E1UU

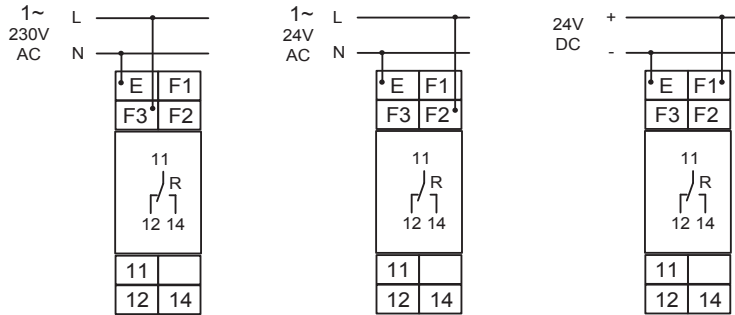

Width 17,5mm

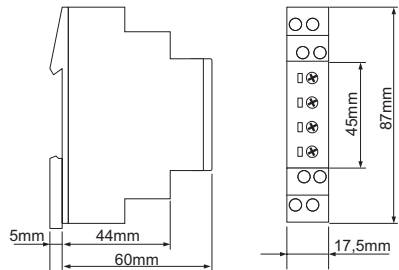

### Functions



- AC/DC current monitoring (E3IM)
- AC current monitoring (E1IM; E1IU)
- Multifunction (E1IM; E3IM)
- Undercurrent monitoring (E1IU)
- Supply voltage 230V (E3IM - galvanically separated)
- 1 CO contact; 2 CO contacts
- Width 17,5mm; 35mm
- Installation design

## Sensing & Monitoring Relays Series ENYA

Current monitoring

WatchDog



### Connections

types

E3IM10AL20

E1IM10AAAL10

E1IU5AAC01

E1IU500mAAC01



Art.No. (PQ1)

1341200

1340200

1340201

1340204

Art.No. (PQ10)

-

-

-

-

EAN13-Code

900866200594

900866200486

900866200504

9008662005341

Measured variable

Current  
AC/DC Sinus (16 to 400Hz)  
100mA AC/DC; terminals k-11  
1A AC/DC; terminals k-12  
10A AC/DC; terminals k-13

Current  
AC Sinus (48 to 63Hz)  
10A AC; terminals Li-Lk

Current  
AC Sinus (48 to 63Hz)  
5A AC; terminals Li-Lk

Current  
AC Sinus (48 to 63Hz)  
500mA AC; terminals Li-Lk

Measuring ranges

Start • Max • Min • Function • Delay

Delay • Max • Min • Function

I<sub>s</sub>

I<sub>s</sub>

Indicators (LEDs)

U/t • Max • Min • R

U/t • Max • Min • R

U • R

U • R

Functions

OVER  
OVER+LATCH  
UNDER  
UNDER+LATCH  
WIN  
WIN+LATCH

OVER  
OVER+LATCH  
UNDER  
UNDER+LATCH  
WIN  
WIN+LATCH

UNDER

UNDER

Switching threshold max.

10% to 100% of I<sub>N</sub>

10% to 100% of I<sub>N</sub>

-

-

Switching threshold min.

5% to 95% of I<sub>N</sub>

5% to 95% of I<sub>N</sub>

10% to 100% of I<sub>N</sub>

10% to 100% of I<sub>N</sub>

Hysteresis

adjustable

adjustable

fixed, 10%

fixed, 10%

Tripping delay

0,1s to 10s

0,1s to 10s

-

-

Start-up suppression time

0s to 10s

-

-

-

Fault latch

selectable

selectable

-

-

Supply

230V AC  
terminals A1-A2  
-15% to +15%

230V AC  
terminals Li-N  
-15% to +15%

230V AC  
terminals Li-N  
-15% to +15%

230V AC  
terminals Li-N  
-15% to +15%

Output

2 CO contacts  
250V, 5A AC

1 CO contact  
250V, 5A AC

1 CO contact  
250V, 5A AC

1 CO contact  
250V, 5A AC

Width

35mm

17,5mm

17,5mm

17,5mm

Certificates

CE

CE • cULus • GOST

CE • cULus • GOST

CE • cULus • GOST

Mechanical design

Self-extinguishing plastic housing, IP rating IP40 • Mounted on DIN-Rail TS 35 in accordance with EN 60715 • Mounting position any • Shockproof terminal connection according to VBG 4 (PZ1 required), IP rating IP20 • Tightening torque max. 1Nm

Terminal capacity

1 x 0,5 to 2,5mm<sup>2</sup> with/without multicore cable end • 1 x 4mm<sup>2</sup> without multicore cable end • 2 x 0,5 to 1,5mm<sup>2</sup> with/without multicore cable end • 2 x 2,5mm<sup>2</sup> flexible without multicore cable end

Ambient conditions

Ambient temperature: -25 to +55°C (in accordance with IEC 60068-1) • Storage temperature: -25 to +70°C • Transport temperature: -25 to +70°C • relative humidity: 15% to 85% (in accordance with IEC 60721-3-3 class 3K3) • Pollution degree: 2 (in accordance with IEC 60664-1)

Accessories

Mounting plate MP; Current transformer Series DSW and WSW

### Dimensions

**E11M:** DC current monitoring with adjustable thresholds, hysteresis and tripping delay.  
**E31M:** AC/DC current monitoring with adjustable thresholds, hysteresis and tripping delay.

OVER	Overcurrent monitoring
UNDER	Undercurrent monitoring
WIN	Monitoring the window between Min and Max
OVER+Latch	Overcurrent monitoring with fault latch
UNDER+Latch	Undercurrent monitoring with fault latch
WIN+Latch	Monitoring the window between Min and Max with fault latch

**E11U**  
 AC current monitoring with adjustable threshold and fixed hysteresis.

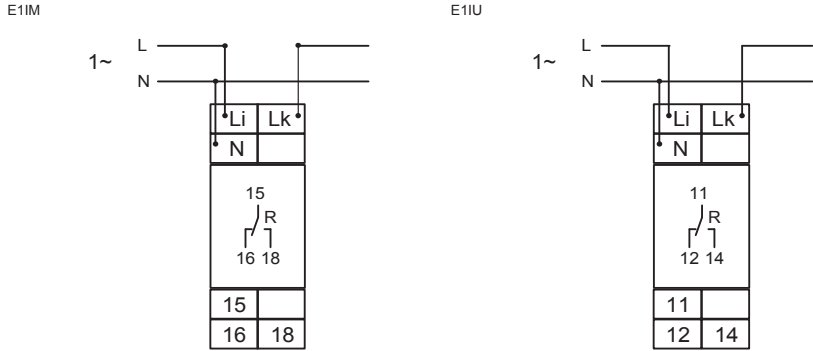

E31M measuring range 100mA; 1A; 10A

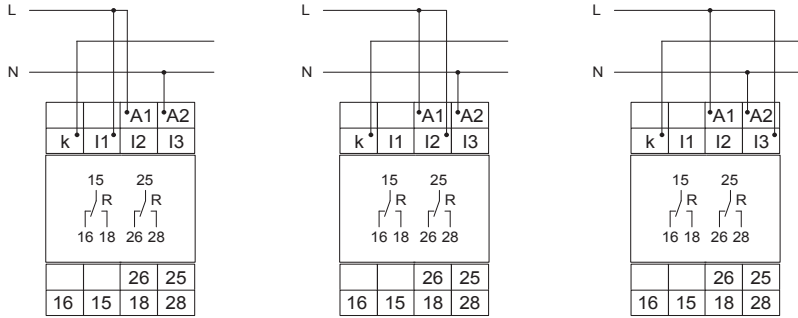

Width 17,5mm

Width 35mm

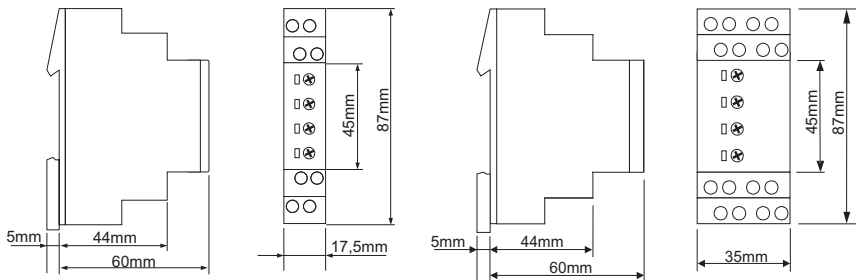

Functions



Sensing & Monitoring Relays Series ENYA



Temperature monitoring

- Temperature monitoring of the motor winding for temperature sensors in accordance with DIN 44081
- Maximum 6 PTC sensors
- Short circuit monitoring of the thermistor line (selectable by means of terminals)
- Optional evaluation of one thermal contact
- Test function with integrated reset key
- Rated isolated voltage on the sensor circuit up to 690V
- 1 CO contact
- Width 35mm
- Installation design

Connections

types

E3TF01



Art.No. (PQ1)	1341600
Art.No. (PQ10)	-
EAN13-Code	900866200512
Measured variable	PTC (motortemperature) max. 6 PTC probes
Measured range	total resistance cold <1,5kΩ terminals T1-T2 or T1-T3
Measuring voltage	≤7,5V DC by R ≤4,0kΩ (in accordance with EN 60947-8)
Controls	Test/Reset button
Indicators (LEDs)	U • Failure
Functions	Overtemperature
Response value	≥3,6kΩ
Release value	≤1,65kΩ
Short circuit monitoring	<20Ω
Fault latch	yes
Reset	internal or external terminals R1-R2
Supply	230V AC terminals A1-A2
Output	1 CO contacts 250V, 5A AC
Dimensions	35mm
Certificates	CE • cULus • GOST
Mechanical design	Self-extinguishing plastic housing, IP rating IP40 • Mounted on DIN-Rail TS 35 in accordance with EN 60715 • Mounting position any • Shockproof terminal connection according to VBG 4 (PZ1 required), IP rating IP20 • Tightening torque max. 1Nm
Terminal capacity	1 x 0,5 to 2,5mm <sup>2</sup> with/without multicore cable end • 1 x 4mm <sup>2</sup> without multicore cable end • 2 x 0,5 to 1,5mm <sup>2</sup> with/without multicore cable end • 2 x 2,5mm <sup>2</sup> flexible without multicore cable end
Ambient conditions	Ambient temperature: -25 to +55°C (in accordance with IEC 60068-1) • Storage temperature: -25 to +70°C • Transport temperature: -25 to +70°C • relative humidity: 15% to 85% (in accordance with IEC 60721-3-3 class 3K3) • Pollution degree: 2 (in accordance with IEC 60664-1)
Accessories	-

Connections

Dimensions

**E3TF01**  
 Temperature monitoring of the motor winding (max. 6 PTC) with fault latch for temperature sensors in accordance with DIN 44081, short circuit monitoring of the thermistor line (selectable by means of terminals), integrated test/reset key.

Note:  
 Only one of this circuit versions (either monitoring of the temperature sensor or monitoring of the thermal contact) can be executed.

Monitoring Temperature sensor

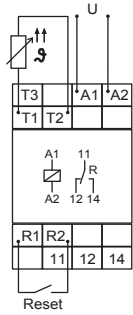

Monitoring Thermal contact

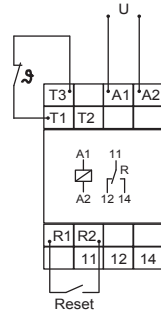

Width 35mm

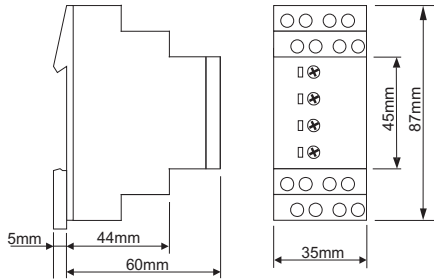

Functions



Sensing & Monitoring Relays Series ENYA



Level monitoring

- Level monitoring of conductive liquids
- Multifunction
- Reinforced insulation of the measuring circuit
- 1 CO contact
- Width 35mm
- Installation design

Connections

types

E3LM10



Art.No. (PQ1)  
 Art.No. (PQ10)  
 EAN13-Code  
 Measured variable

1341500  
 -  
 900866200509

Measured range  
 Probe voltage  
 Probe current  
 Wiring distance

level with  
 conductiv probe  
 0,25 to 100kΩ  
 12V AC  
 max. 7mA

Control  
 Indicators (LEDs)

max. 1000m (adjustment <50%)  
 max. 100m (adjustment <100%)  
 capacity of cable 100nF/km  
 Delay ON • Delay OFF • Sensitivity • Function  
 U • R

Functions

Pump up  
 Pump down

trigger level  
 Tripping delay  
 Turn-off delay  
 Supply

0,25 to 100 kΩ (Sensitivity)  
 0,5s to 10s  
 0,5s to 10s  
 230V AC  
 terminals A1-A2

Output  
 Width

1 CO contact  
 250V, 5A AC  
 35mm

Certificates  
 Mechanical design

CE • cULus • GOST

Terminal capacity

Self-extinguishing plastic housing, IP rating IP40 • Mounted on DIN-Rail TS 35 in accordance with EN 60715 • Mounting position any • Shockproof terminal connection according to VBG 4 (PZ1 required), IP rating IP20 • Tightening torque max. 1Nm

1 x 0,5 to 2,5mm<sup>2</sup> with/without multicore cable end • 1 x 4mm<sup>2</sup> without multicore cable end • 2 x 0,5 to 1,5mm<sup>2</sup> with/without multicore cable end • 2 x 2,5mm<sup>2</sup> flexible without multicore cable end

Ambient conditions  
 Accessories

Ambient temperature: -25 to +55°C (in accordance with IEC 60668-1) • Storage temperature: -25 to +70°C • Transport temperature: -25 to +70°C • relative humidity: 15% to 85% (in accordance with IEC 60721-3-3 class 3K3) • Pollution degree: 2 (in accordance with IEC 60664-1)  
 Conductive probes (types SK1, SK2, SK3)

Dimensions

Ambient conditions  
 Accessories

### E3LM10

Level monitoring of conductive liquid, timing for tripping delay and turn-off delay separately adjustable and the following functions (selectable by means of rotary switch):

Pump up                    pump up or minimum monitoring  
Pump down                pump down or maximum monitoring

### Functions

### E3LM

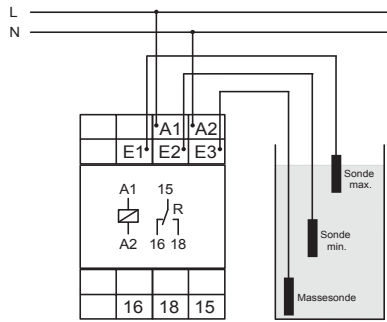

### Connections

### With 35mm

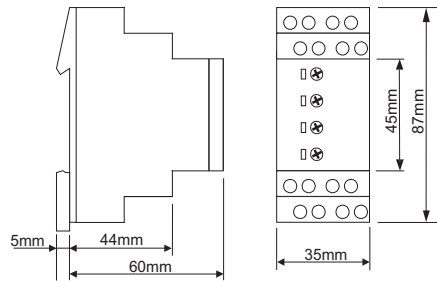

### Dimensions